

SEL-487B

Bus Differential and Breaker Failure Relay



Advanced bus protection with built-in breaker failure detection

- Protect busbars with up to 21 terminals using high-speed, low-impedance bus differential elements.
- Transform the way you modernize your substation with SEL Time-Domain Link (TiDL[®]) and Sampled Values (SV) technologies.
- Implement distributed bus protection and simplify commissioning using TiDL technology.
- Improve system testing and post-fault analysis with comprehensive monitoring, metering, and event recording capabilities.



Functional Overview

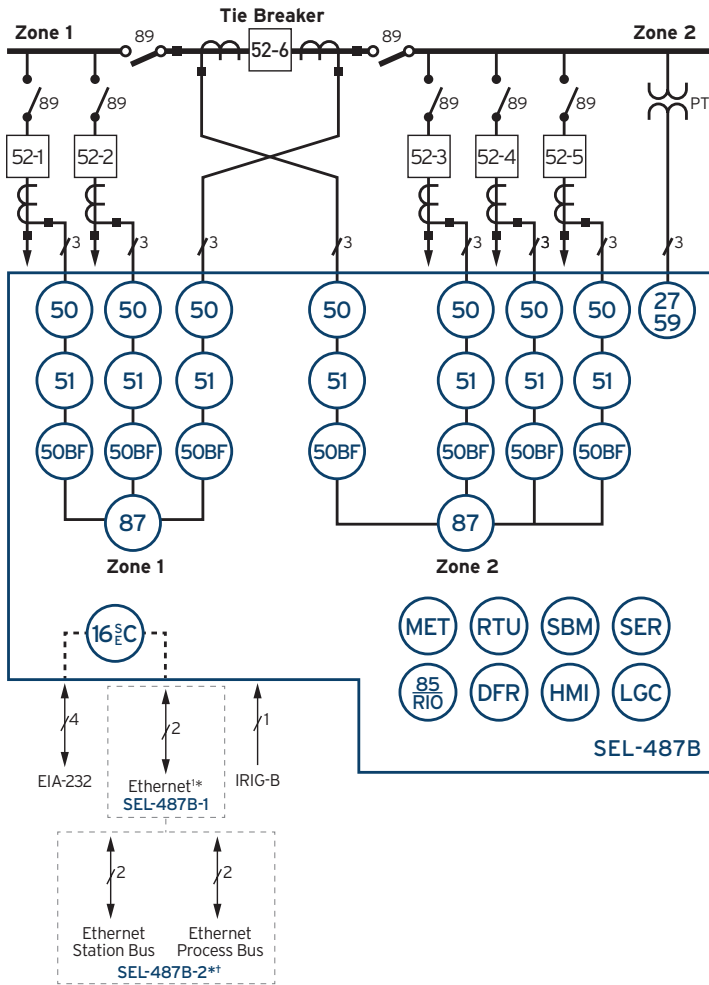

ANSI Number/Acronyms and Functions

16 SEC	Access Security (Serial, Ethernet)
27/59	Over-/Undervoltage
50	Overcurrent
50BF	Breaker Failure Overcurrent
51	Time-Overcurrent
85 RIO	SEL MIRRORED BITS® Communications
87	Current Differential
DFR	Event Reports
HMI	Operator Interface
LGC	Expanded SELogic® Control Equations
MET	High-Accuracy Metering
RTU	Remote Terminal Unit
SER	Sequential Events Recorder

Additional Functions

SBM	Station Battery Monitor
SV	IEC 61850-9-2 Sampled Values Technology*†
TiDL	Time-Domain Link Technology*†

†Copper or fiber-optic *Optional feature

†TiDL and SV relays receive current and voltage values from remote merging units.



Key Features

Low-Impedance Bus Differential Protection

The SEL-487B Bus Differential and Breaker Failure Relay protects bus systems with up to 21 terminals (21 CTs per relay, 63 CTs with a three-relay scheme), 6 protection zones, and 3 independent check zones. To optimize protection security, each check zone supervises a designated phase in the system and a patented open-CT detection algorithm blocks potential misoperations during open- or shorted-CT conditions. Differential and directional current elements provide increased security and fast fault detection. You can also reduce protection costs with built-in breaker failure protection.

Flexibility

Implement different ratio CTs and nondedicated CTs with the SEL-487B. The flexibility built into the settings allows you to eliminate complex wiring by using CT ratios that differ by up to a factor of 10:1. Take advantage of the same CTs for differential protection, metering, backup relaying, and other functions.

Monitoring and Metering

The SEL-487B provides accurate, timely monitoring and metering of busbar, feeder, and substation signals. Terminal currents, breaker and disconnect positions, station dc voltage levels, and three-phase voltage are continuously monitored and updated. The relay also provides event reports and Sequential Events Recorder (SER) reports to simplify post-fault event analysis.

Digital Secondary System Technologies

Modernize your substation by applying SEL TiDL technology or SEL SV technology. Both of these digital secondary system solutions replace copper wires with fiber-optic cables to increase safety, reduce costs associated with using copper wires, and limit the impact of electromagnetic interference.

TiDL is a simple and secure point-to-point solution that is easy to implement, with no external time source or network engineering required. SEL-TMU TiDL Merging Units placed in the yard digitize signals and transmit them over fiber-optic cables to the SEL-487B-2 TiDL relay in the control house.

SEL SV combines protection in the merging unit with the flexibility of IEC 61850-9-2 to increase power system reliability. SEL SV merging units (or other IEC 61850-9-2 SV-compliant units) digitize signals and transmit them via Ethernet over fiber-optic cables to an SEL-487B-2 SV relay in the control house.

Distributed Bus Protection

Apply the SEL-487B in a distributed bus protection scheme using TiDL technology. The system is easily scalable based on the number of bays in your system, and it does not require special communications ports or network engineering. TiDL's point-to-point architecture simplifies fiber-optic cable routing in the field and makes the commissioning process quick and easy.

Product Overview

EIA-232 front serial port is quick and convenient for system setup and local access.

Easy-to-use keypad aids simple navigation.

Front-panel LEDs indicate custom alarms and provide fast and simple information to assist dispatchers and line crews with rapid power restoration.

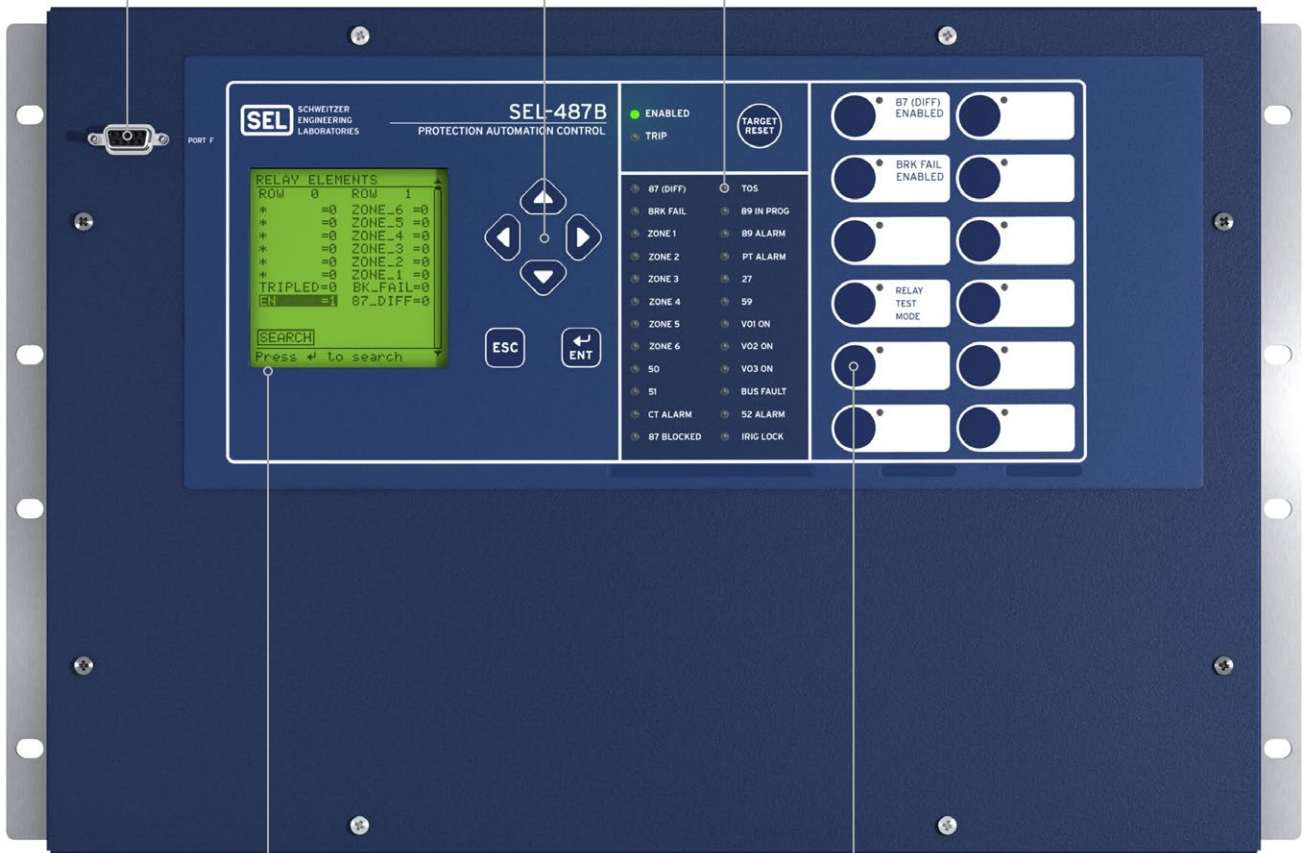

LCD automatically scrolls between custom displays.

Programmable operator pushbuttons with user-configurable labels allow front-panel customization.

Communications protocols include FTP, Telnet, DNP3 LAN/WAN, the Parallel Redundancy Protocol (PRP), the IEEE 1588 Precision Time Protocol Version 2 (PTPv2),** and IEC 61850 Edition 2.*

Choose from a horizontal panel-mount or rack-mount chassis and different size options.

Use one front and three rear EIA-232 ports for MIRRORING BITS communications, DNP3, SCADA, and engineering access.

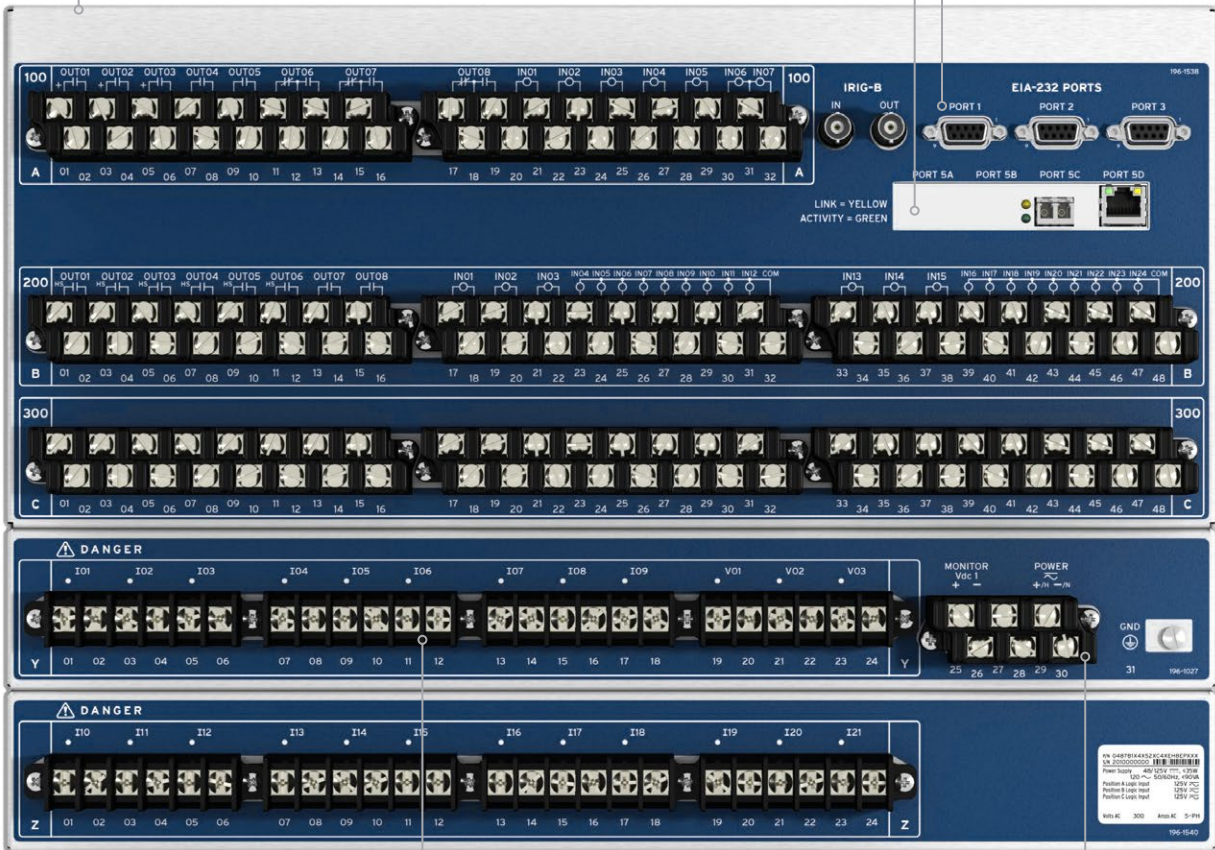

21 current and 3 voltage channels accommodate different busbar configurations.

Choose from power supply options such as 24–48 Vdc; 48–125 Vdc or 110–120 Vac; or 125–250 Vdc or 110–240 Vac.

*Optional feature.

**For PTPv2 implementation, Ports 5A and 5B must be ordered as an option.

Applications

Differential Protection

The SEL-487B includes six independent current differential elements, and each one provides:

- Fast operate times for all busbar faults.
- Security for external faults with heavy CT saturation.
- Security with subsidence current present.
- High sensitivity to busbar faults.
- Minimum delay for faults evolving from external to internal.

CT Supervision

For each zone, sensitive current differential elements detect differential current resulting from a differential element that is not well-balanced (i.e., has wrong CT ratios). If the conditions persist for longer than a user-specified delay, the element asserts an alarm that you can use to generate an external alarm and/or block the zone.

Advanced Open-CT Detection Logic

The patented open-CT detection logic improves the security of the current differential element. It ensures current differential bus zones will not misoperate due to terminals that cannot be properly measured. This advanced logic blocks differential element misoperations that occur under open- or shorted-CT conditions. The open-CT detection logic monitors the CT terminals in every bus zone to detect when a contributing CT fails.

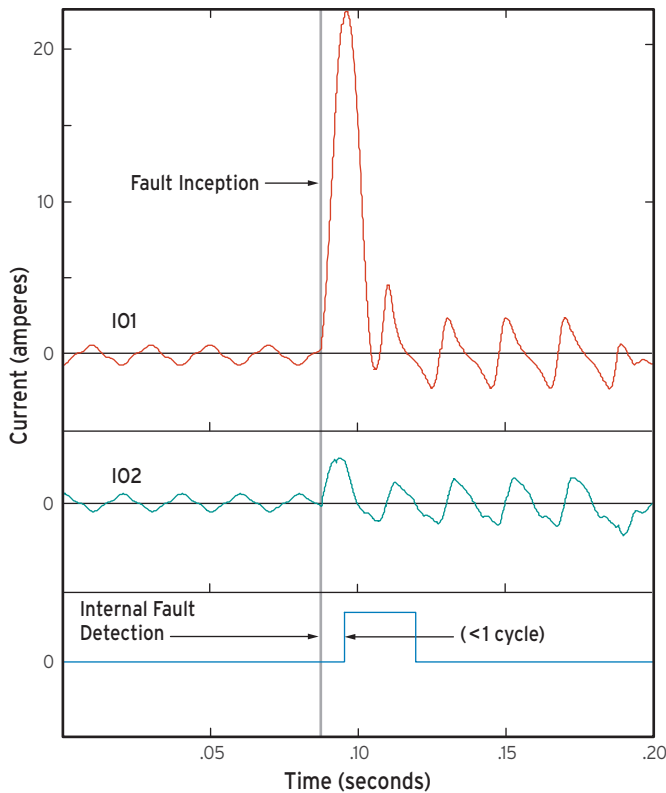

Differential element operates in less than one cycle for internal faults.

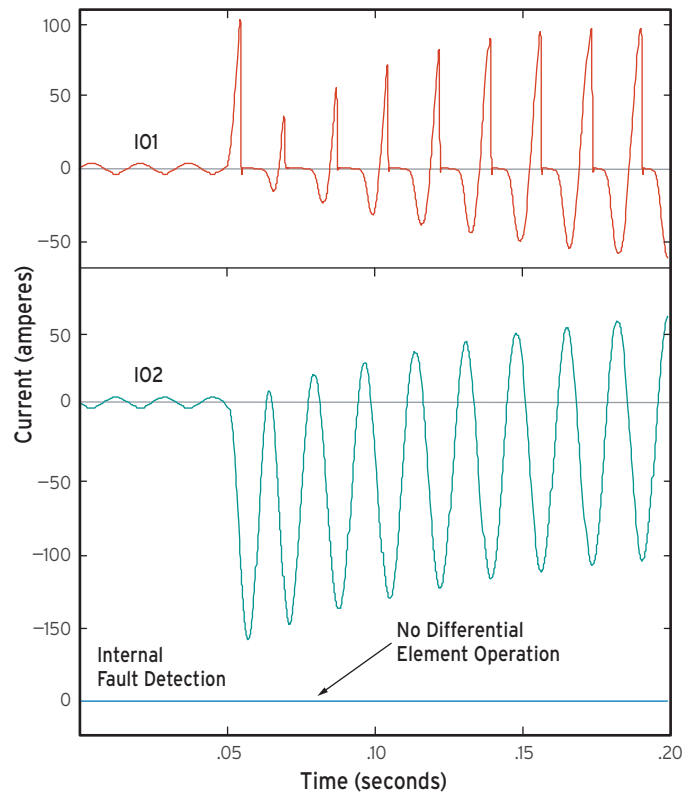

Differential element remains secure for external faults with heavy CT saturation.

Voltage Elements

Supervise current differential tripping within the relay by using voltage elements. Three separate voltage elements consist of two levels of phase under- and overvoltage elements and two levels of negative- and zero-sequence overvoltage elements for each of the three analog voltage quantities measured.

Integrated Overcurrent Protection

Ten overcurrent curves are available for each current input. Each torque-controlled time-overcurrent element has two reset characteristics. There is also one level of instantaneous and definite-time elements available for each current input.

Breaker Failure Detection

The SEL-487B includes complete breaker failure protection, with retrip capability for each terminal. Internal breaker failure is determined by predefined protection schemes that allow different types of trip signals and current flow conditions. You can set any terminal to either internal or external breaker failure protection; the inputs can provide individual or identical responses to each breaker failure condition.

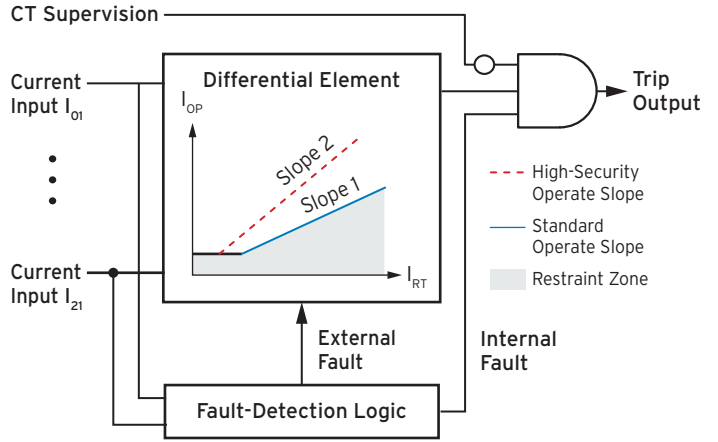

When the relay directional elements detect an external fault, the relay enters a high-security mode and dynamically selects a higher slope for the differential elements, making them more secure during the fault.

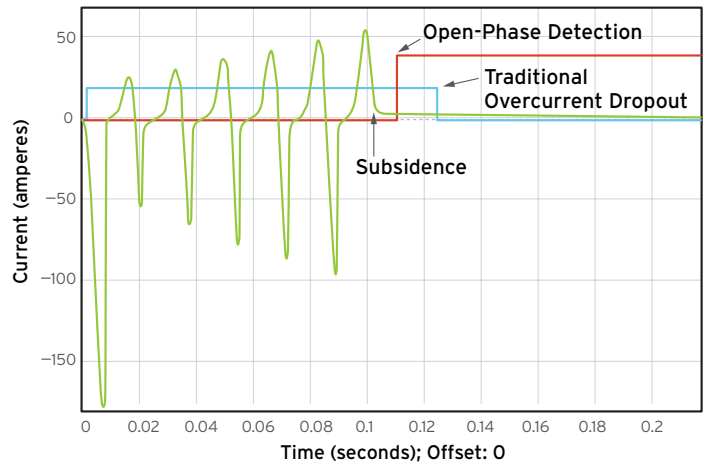

High-speed open-pole detection logic detects open-pole conditions in fewer than 0.75 cycles to reduce breaker failure coordination times.

Dynamic Zone Configuration

The SEL-487B dynamically assigns the input currents to the correct differential elements without the need for additional auxiliary relays. Connect the digital inputs from the busbar disconnect and breaker auxiliary contacts directly to the relay. SELogic control equations and zone selection logic will correctly assign the currents to the differential elements, even for complex bus arrangements (see top example).

Note that the SEL-487B automatically includes the Zone 4 currents in Zone 3 when disconnect switch DS3 is closed (see middle example).

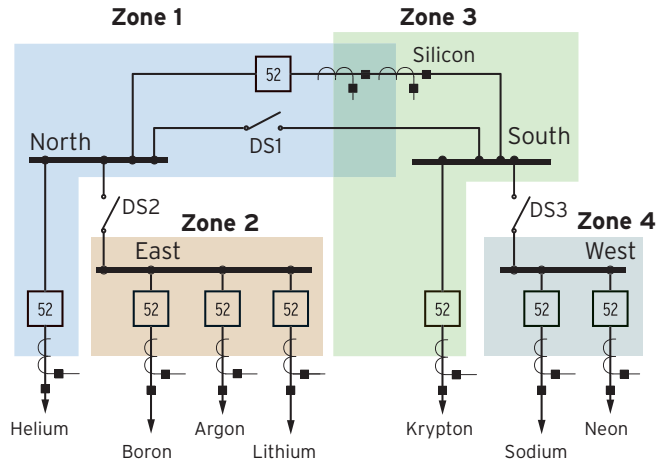

Result of ZONE Command:

```
=>> ZONE
BUS PROTECTION
Rinadel Station
Terminals in Protection Zone 1
HELIUM SILICON
Bus Zones in Protection Zone 1
NORTH
Terminals in Protection Zone 2
BORON ARGON LITHIUM
Bus Zones in Protection Zone 2
EAST
Terminals in Protection Zone 3
SILICON KRYPTON
Bus Zones in Protection Zone 3
SOUTH
Terminals in Protection Zone 4
SODIUM NEON
Bus Zones in Protection Zone 4
WEST
=>>
```

Three Independent Check Zones Supervise up to Six Differential Bus Zones

In complex busbar layouts, the SEL-487B uses disconnect auxiliary contact status to define current differential bus zones and supervises these zones on a per-phase basis with the independent "check zone" feature to prevent misoperation due to a discrepancy.

The check zone feature:

- Allows you to create your own custom applications using powerful SELogic control equations.
- Provides secure supervision for bus zones.
- Supervises bus zones on a per-phase basis, independent of the terminal auxiliary disconnect status.
- Processes its logic independently of all bus zones.
- Fits a wide variety of applications and protection philosophies, with independent pickup and slope settings.

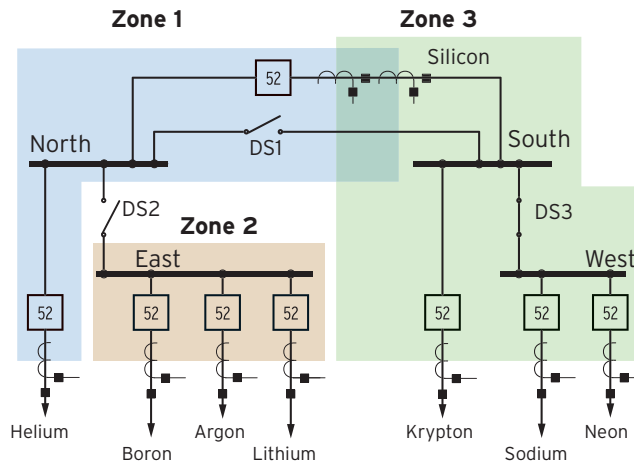

Result of ZONE Command:

```
=>> ZONE
BUS PROTECTION
Rinadel Station
Terminals in Protection Zone 1
HELIUM SILICON
Bus Zones in Protection Zone 1
NORTH
Terminals in Protection Zone 2
BORON ARGON LITHIUM
Bus Zones in Protection Zone 2
EAST
Terminals in Protection Zone 3
SILICON KRYPTON SODIUM NEON
Bus Zones in Protection Zone 3
SOUTH WEST
=>>
```

Three-Relay Bus Protection

Application—For up to 21 Terminals

You can configure a check zone for every phase, encompassing all terminals at the station (except bus coupler and sectionalizing breakers), independent of the disconnect auxiliary contact status.

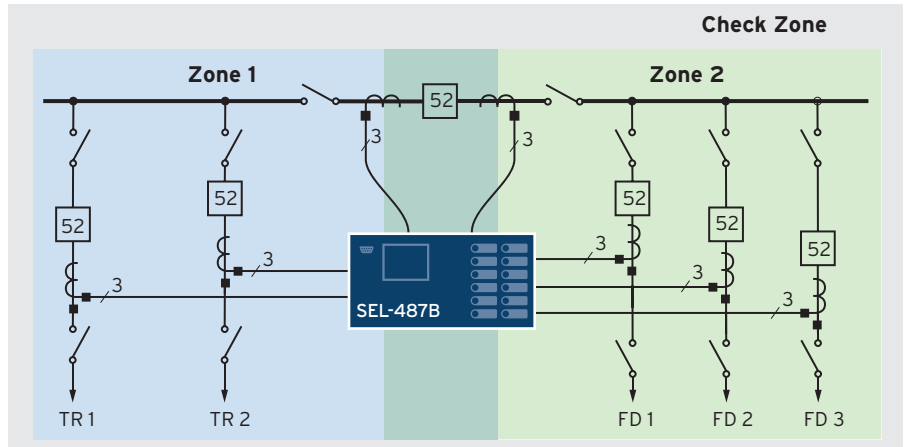

This example shows a single SEL-487B protecting a system with two 3-phase bus zones and increasing security by applying a check zone per phase.

Automation and Control

With 32 local control points, the SEL-487B helps eliminate traditional panel control switches. You can set, clear, or pulse local control points with the programmable front-panel pushbuttons and display. Using SELogic control equations, you can program the local control points to implement your control scheme.

The 32 remote control points help eliminate remote terminal unit (RTU)-to-relay wiring. Using serial port commands, you can set, clear, or pulse remote control points. You can also incorporate the remote control points into your control scheme via SELogic control equations and apply remote control points for SCADA-type control operations, such as trip and group selection.

The SEL-487B control logic can replace the following:

- Traditional panel control switches
- RTU-to-relay wiring
- Traditional latching relays
- Traditional indicating panel lights
- Panel meters

SEL TiDL Process Bus Solutions

SEL Time-Domain Link (TiDL) technology is a protection-centered digital secondary system solution engineered with simplicity in mind. This technology minimizes cybersecurity risks and network engineering by using point-to-point communications and a nonroutable protocol. A TiDL-based solution does not require an external time reference.

Simple Architecture

SEL-TMU devices are placed in the yard close to the primary equipment and digitize discrete I/O signals and analog data, such as voltages and currents. These data are then transported over fiber-optic cables to an SEL-487B-2 TiDL relay in the control house. The point-to-point architecture simplifies implementation and drives overall maintenance and maintenance costs down.

Data-Sharing Capabilities

Each SEL-TMU can be paired with up to four SEL-400 series TiDL relays. This data-sharing capability allows design flexibility, and point-to-point connections simplify system expansion.

Built-In Data Synchronization

TiDL relays measure the path delay between the relay and the merging unit on each connected port to align current and voltage measurements acquired from different merging units. This eliminates the need for external time sources, such as GPS clocks, for synchronization.

All data from the SEL-TMU devices are synchronized with each other regardless of the number of units connected to the SEL-487B-2 relay or the length of the fiber.

Strong Cybersecurity Posture

The dedicated, deterministic TiDL system helps secure mission-critical systems. The isolated point-to-point connections and the absence of switches and routers reduce the electronic security perimeter and limit attack points. This security-minded architecture prevents remote access, and its simplicity eliminates the need for managing port access.

Minimal Training Required

The relay settings for the SEL-487B-2 TiDL relay are the same as those in all popular SEL-400 series models, providing consistency and simplicity. You can use the same protection schemes and applications for complete feeder protection.

Flexible Communications Options

The SEL-487B can be configured with a five-port Ethernet card supporting PRP or failover functionality to increase system availability. Use PTPv2 on process bus or station bus ports to provide time synchronization.

This card also features dedicated ports and IP addresses for station bus and engineering access networks to provide selective access control.

Use small form-factor pluggable (SFP) transceivers on process bus, station bus, and engineering access ports. Single- and multimode communications options provide increased flexibility.

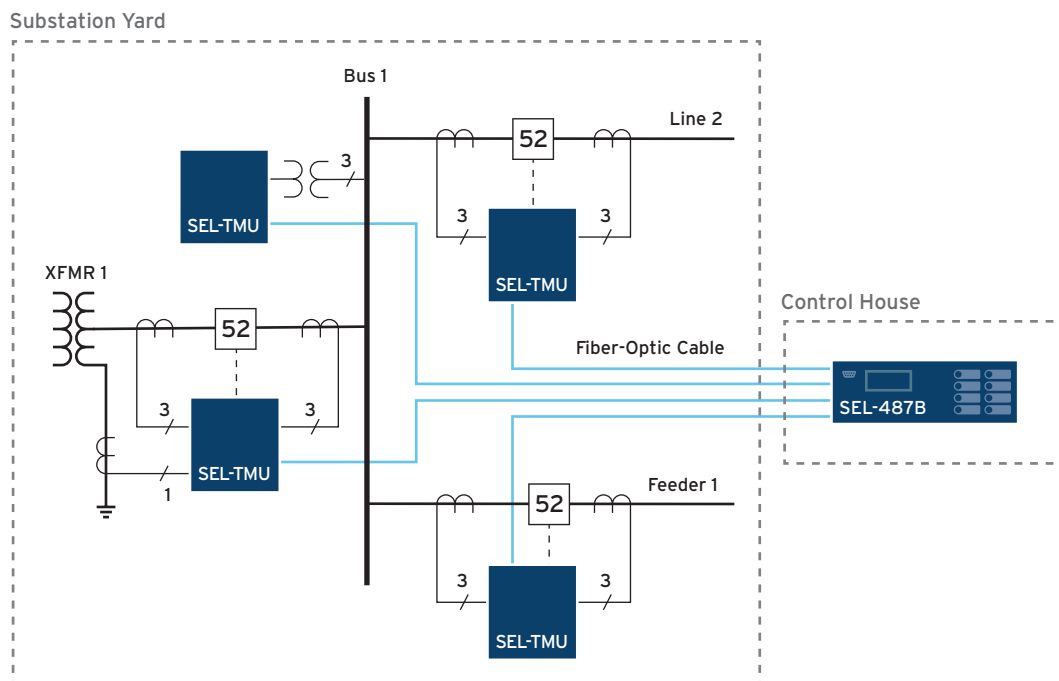

SEL-487B-2 With TiDL Technology

4U chassis with horizontal mounting options (panel or rack) accommodates your application needs.

Select a five-port Ethernet card for dedicated station bus and engineering access ports.

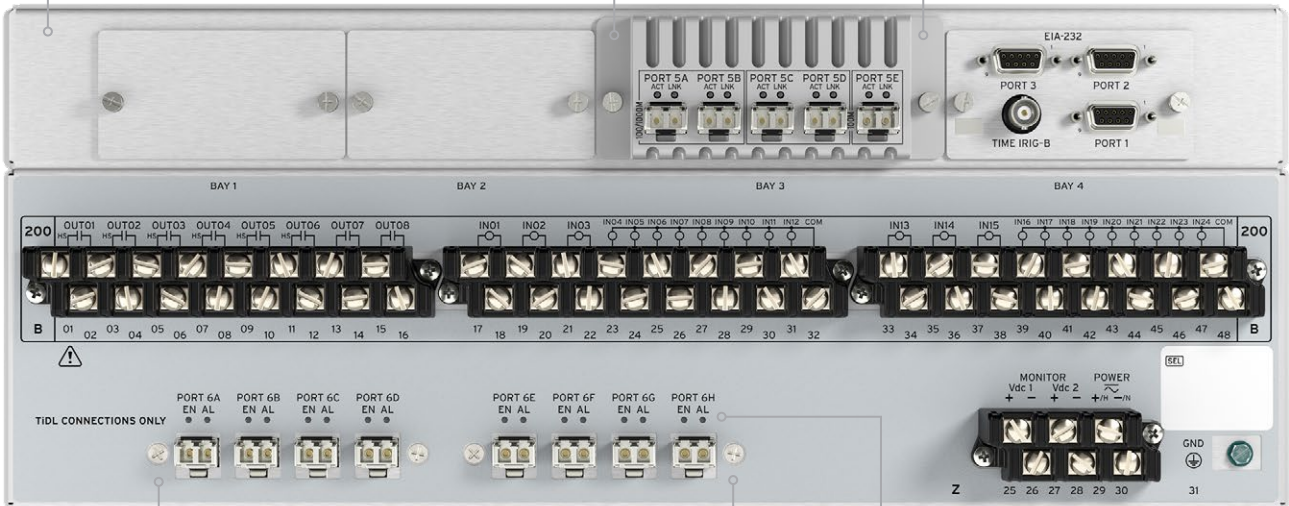

Eight SFP ports allow the TiDL relay to connect with eight remote SEL-TMU devices and to receive remote analog and digital data.

LEDs for viewing the connection status to an SEL-TMU on a per-port basis.

SEL SV-Based Process Bus Solutions

SEL Sampled Values (SV)-based solutions are communications-centric, network-based solutions that combine protection in the merging unit with the flexibility of IEC 61850-9-2.

Networked Architecture

The SEL-487B-2 SV relay (subscriber) in the control house receives digitized analog signals from SV merging units (publishers) in the yard via a fiber-based Ethernet network. SEL SV-based solutions allow you to create a flexible Ethernet-based network using tools such as software-defined networks or VLANs. You can use SEL software-defined networking (SDN) switches to provide centralized traffic engineering and improve Ethernet performance. SEL SDN switches act as transparent PTP clocks that support IEEE C37.238 power system profile, ensuring submicrosecond time synchronization of the end devices.

Merging Units With Built-In Protection

Some SEL relays can be used as SV merging units. Apply the SEL-401 Protection, Automation, and Control Merging Unit for overcurrent and breaker failure protection. Use the SEL-421 Protection, Automation, and Control Merging Unit for complete line protection, including five zones of subcycle mho and quadrilateral distance elements. If IEC 61850 network communications are lost, the SEL merging units provide backup standalone protection.

Interoperability

SEL-487B-2 SV relays and other SEL SV devices are fully compliant with IEC 61850-9-2 and the UCA 61850-9-2LE guideline. You can use them with primary equipment that generates SV streams or with other manufacturers' SV-compliant units.

Substation Yard

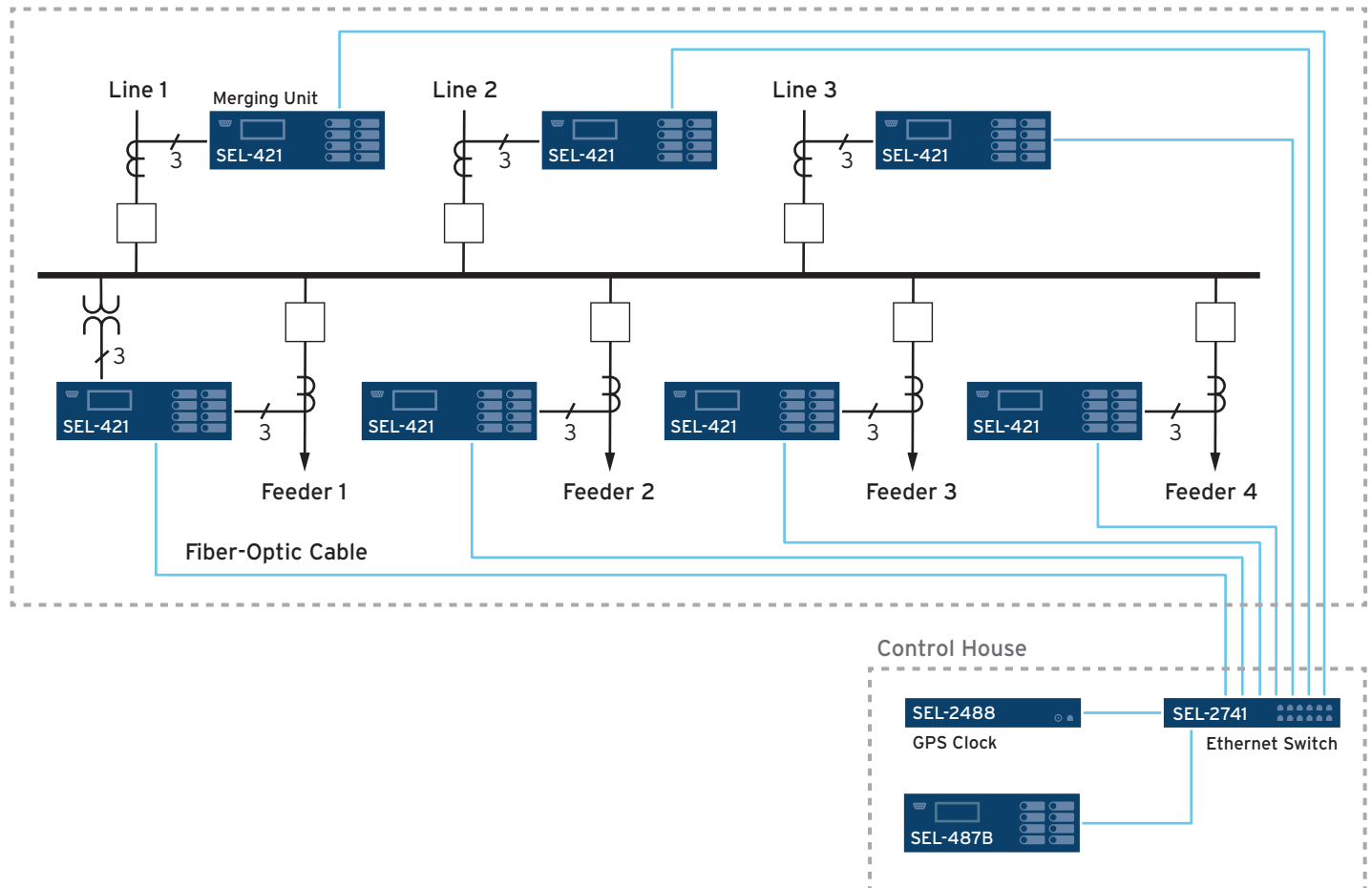

Advanced Network Monitoring and Diagnostic Tools

The SEL-487B-2 SV relay provides advanced network monitoring and diagnostic tools through standard IEC 61850 logical nodes. Additional diagnostic information and statistics are available through COM SV, GOO, ETH, and COM PRP commands, which aid in troubleshooting. The TEST SV command allows you to check the network connectivity as well as the CT and PT ratios between publisher and subscriber devices.

Flexible Communications Options

The SEL-487B can be configured with a five-port Ethernet card supporting PRP or failover functionality to increase system availability. Use PTPv2 on process bus or station bus ports to provide time synchronization.

This card also features dedicated ports and IP addresses for station bus and engineering access networks to provide selective access control.

Use SFP transceivers on process bus, station bus, and engineering access ports. Single- and multimode communications options provide increased flexibility. All ports support 100 Mbps SFPs, and process bus ports also support 1 Gbps SFPs.

SEL-487B-2 With SV Technology

Select a five-port Ethernet card for dedicated process bus, station bus, and engineering access ports.

The 4U chassis has various mounting options to accommodate hardware needs.

Choose an SFP transceiver to match application requirements. Process bus ports support 100 Mbps and 1 Gbps connections. Station bus and engineering access support 100 Mbps connections. Select single- or multimode fiber.



Accessibility and Communications

Simplify System Testing and Post-Fault Analysis

The SEL-487B event-reporting capabilities help improve understanding of even the most complex protective scheme operations. With the oscillographic and binary COMTRADE event reports and SER reporting in the SEL-487B, you can eliminate the need for external recorders or meters.

View SER Records

Gain a broad perspective of relay element operation with the SER in the SEL-487B. Items that trigger an SER entry are selectable and can include as many as 250 monitoring points, such as input/output change of state or element pickup/dropout. The relay SER stores the latest 1,000 events, which are available through the SER command. The latest 200 events are also viewable via the front-panel LCD.

Access Useful Information

The SEL-487B makes it easy to access useful information when and where you need it.

- Metering quantities include primary and secondary voltage and current magnitudes as well as angles for each terminal.
- Zone information displays the primary or secondary current and voltage for each terminal. The polarity of each CT and the bus zones in each of the protective zones at the station are also included.
- Differential metering shows the operating and restraint currents for each zone as well as the reference current.
- Battery monitoring provides warning and alarm thresholds that you can monitor with the SEL-2032 Communications Processor and the SEL-3530 Real-Time Automation Controller (RTAC). You can also set up the system to send status messages to a local display, phones, or other devices.

Ethernet-Based Communications

An Ethernet communications card enables you to communicate using a variety of protocols, including FTP, HTTP, DNP3, PTPv2, PRP, Telnet, synchrophasors, and IEC 61850 Edition 2. Select between copper, fiber, or a combination of port types.

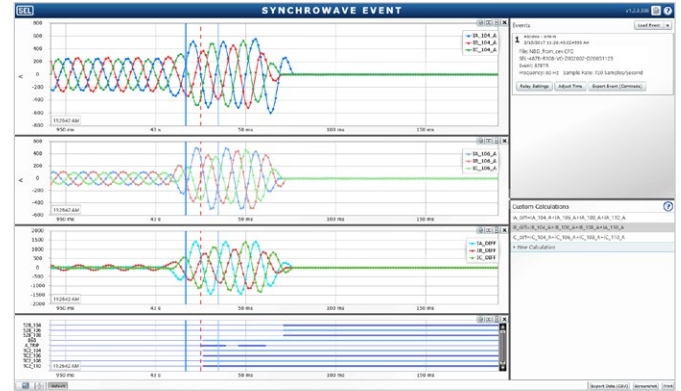

SEL-5601-2 SYNCHROWAVE® Event Software provides powerful analytic capabilities.

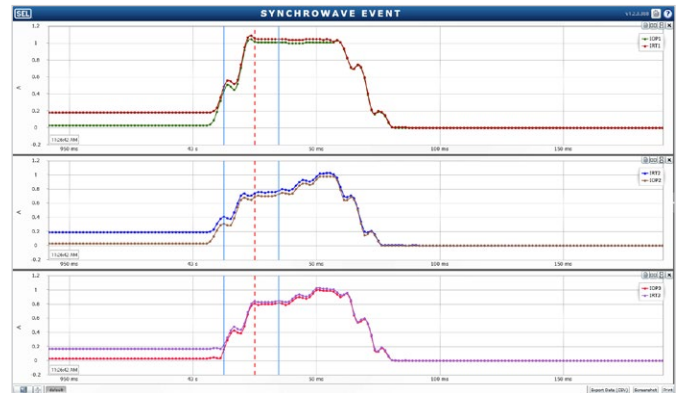

SYNCHROWAVE Event displays individual operate and restraint currents for three different protection zones.

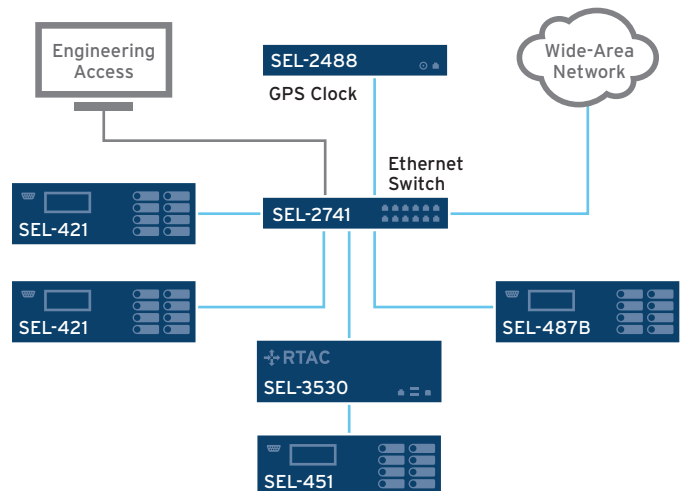

Typical Ethernet network configuration.

Setting and Commissioning Software

Save Time and Eliminate Costly Errors With SEL Commissioning Assistant Software

SEL Commissioning Assistant Software recommends matrix compensation settings after automatically identifying incorrect field wiring and improper CT configurations, such as incorrect CT polarities, inconsistent CT ratios, or crossed phases.

Apply the Commissioning Assistant in Five Easy Steps

1. Define the system one-line diagram.
2. Assign any two windings to conduct a test.
3. Validate the current flow, CT ratios, and polarity.
4. Run the test to start the matrix calculation process.
5. Document and implement the correct compensation matrix recommended for the transformer application.

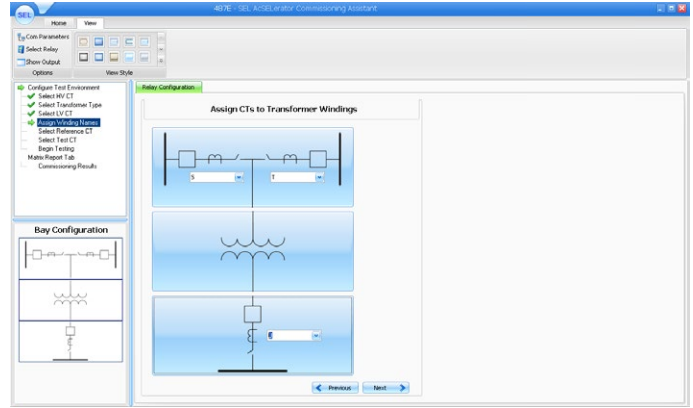

Simplify the SEL-487B Configuration Process With the Graphical Logic Editor (GLE)

With the acSELEATOR QuickSet® SEL-5030 Software GLE, you can view SELoGIC control equations graphically and document settings files for easier validation and commissioning. You can also convert existing SELoGIC control equations to easy-to-read diagrams and save diagrams with your QuickSet software settings.

The GLE makes it easy to design new SELoGIC control equations with the convenient diagram navigation tool, drag-and-drop interface, function block diagrams, and automatic layout function. You can manage your control diagrams with a full element palette. The GLE aids in reducing design errors and reducing the time and expense of commissioning relays.

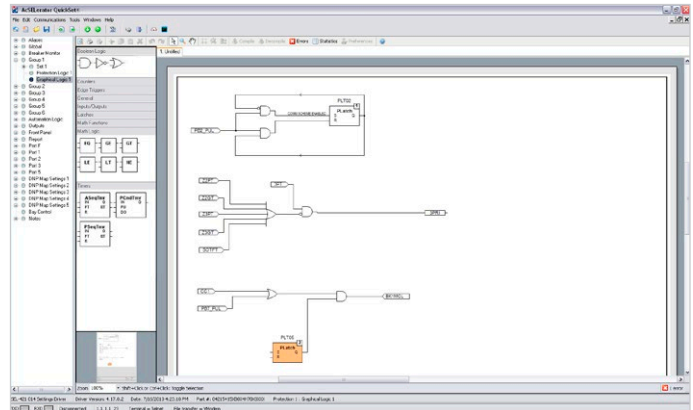

Next-Generation Configuration Software

Included with the TiDL and SV relays, SEL Grid Configurator is a new software tool that allows engineers and technicians to quickly create, manage, and deploy settings for SEL power system devices. It features a modern interface designed for ease of use, with powerful protection visualization and comprehensive reporting to reduce device deployment complexity.

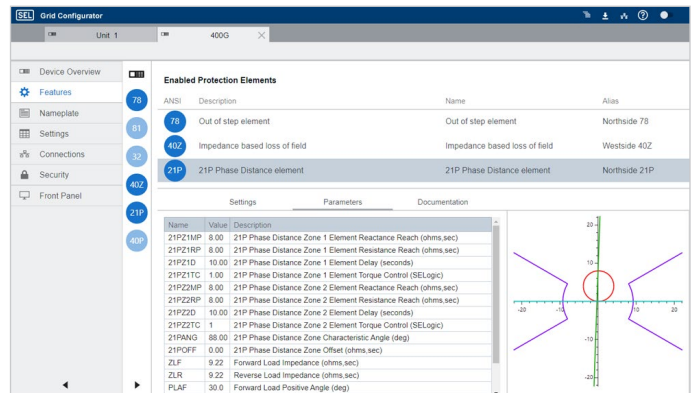

SEL-487B Specifications

General			
AC Current Inputs (21 total)	5 A nominal 1 A nominal	TiDL Ports	Fiber-optic ports: 8 Range: ~2 km Data rate: 100 Mbps Protocol: SEL T-Protocol
AC Voltage Inputs (3 total)	0–300 V _{L-N} operational	SV Ports	Subscriber: As many as 7 SV data streams Data rate: 4.8 kHz for 60 Hz system, 4 kHz for 50 Hz system Protocol: IEC 61850-9-2
Communications Protocols	FTP, Telnet, SEL ASCII, SEL Fast Message, DNP3, PRP, PTPv2, and IEC 61850 Edition 2 (optional)	Precise-Time Input	Demodulated IRIG-B time input and PTPv2
Communications Ports	Serial Ports One front-panel and three rear-panel EIA-232 serial ports 300–57,600 bps Two-Port Ethernet Card Two 100BASE-FX fiber-optic network ports Four-Port Ethernet Card Four 10/100BASE-T twisted-pair network ports, or Four 100BASE-FX fiber-optic network ports, or Two 10/100BASE-T twisted-pair network ports and two 100BASE-FX fiber-optic network ports Five-Port Ethernet Card Two 100/1000BASE SFP ports Three 100BASE SFP ports	Processing	AC voltage and current inputs: 8,000 samples per second Protection and control processing: 12 times per power system cycle
		Power Supply	24–48 Vdc 48–125 Vdc or 110–120 Vac 125–250 Vdc or 110–240 Vac
		Operating Temperature	–40° to +85°C (–40° to +185°F)

SCHWEITZER ENGINEERING LABORATORIES

Making Electric Power Safer, More Reliable, and More Economical
+1.509.332.1890 | info@selinc.com | selinc.com

© 2024 by Schweitzer Engineering Laboratories, Inc.
PF00063 • 20240212

