

**NOVEL APPLICATIONS
OF A
DIGITAL RELAY WITH MULTIPLE SETTING GROUPS**

BY

**DEMETRIOS A. TZIOUVARAS
PACIFIC GAS AND ELECTRIC
SAN FRANCISCO, CALIFORNIA**

**WILLIAM D. HAWBAKER
SCHWEITZER ENGINEERING LABORATORIES, INC.
PULLMAN, WASHINGTON**

**PRESENTED BEFORE THE
17TH ANNUAL
WESTERN PROTECTIVE RELAY CONFERENCE
SPOKANE, WASHINGTON
OCTOBER 23 - 25, 1990**

NOVEL APPLICATIONS OF A DIGITAL RELAY WITH MULTIPLE SETTING GROUPS

INTRODUCTION

The design of buses in high voltage and extra high voltage systems is dictated by the degree of service reliability required, flexibility of system operation, and economics. Bus arrangements such as breaker and a half, ring bus, and double bus-double breaker have been utilized for extra high voltage systems to maintain service reliability and flexible system operation. These bus arrangements allow circuit breaker maintenance without impairing or degrading the required degree of protection.

The bus arrangements mentioned above cannot be economically justified for the majority of high voltage substations. For these substations, utilities provide a substitute circuit breaker which takes the place of the breaker during maintenance and requires the design of complex relay schemes with many compromises to substitute for normal protection.

This paper presents a novel approach in maintaining protection during circuit breaker maintenance and concentrates on applications where breaker and a half or ring bus arrangements cannot be economically justified. It describes the complexity and compromises of the traditional approach and shows how to overcome traditional shortcomings by applying specially designed digital relays with multigroup setting capabilities. It also covers a number of other applications where this type of digital relay could provide improved protection.

BUS-TIE PROTECTION - TRADITIONAL APPROACH

Utilities have utilized bus types in extra high voltage (EHV) and ultra high voltage (UHV) systems which provide a high degree of service reliability and flexibility of system operation. EHV and UHV transmission lines cannot be deenergized for circuit breaker (CB) problems or maintenance because of the importance of these lines to the overall system reliability, integrity, and availability. Common bus types utilized in EHV and UHV systems are the ring type, breaker and a half type, and double bus-double breaker type. These bus types provide different degrees of reliability, but all allow CB maintenance without impairing or degrading required protection. However, for medium and high voltage systems, other bus types have been utilized. For economic reasons, these bus types (shown in Figures 1a, 1b, and 1c) do not provide the highest degree of reliability. The most basic and economical design is that of Figure 1a. This type is used widely at distribution and lower transmission voltages. CB maintenance or problems require that a transmission line or transformer be removed from service.

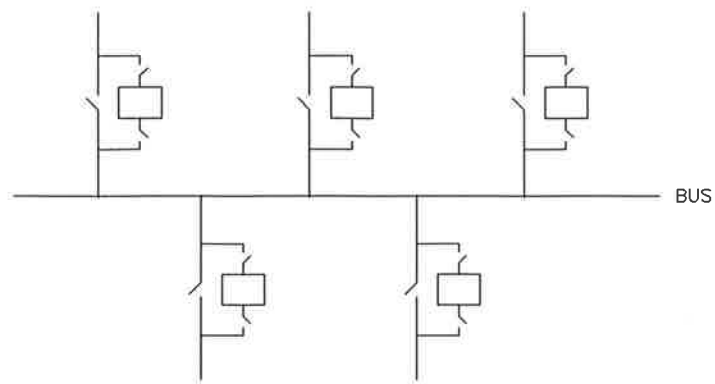

(a) Single Bus

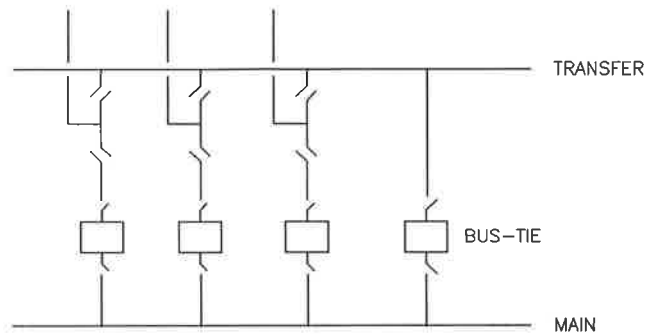

(b) Main and Transfer Bus

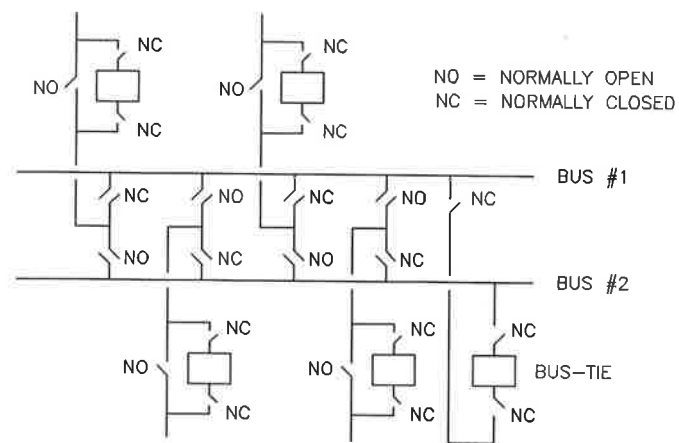

(c) Double Bus - Single Breaker

Figure 1: Common Transmission and Subtransmission Bus Arrangements

At higher transmission voltages where a transmission line cannot be removed from service during CB maintenance or trouble, bus designs such as shown in Figures 1b and 1c have been used. Here, the bus-tie CB acts as a substitute for any of the transmission line or transformer breakers.

PG&E uses the bus type shown in Figure 1b for 60 and 70 kV buses. The bus type in Figure 1c is used extensively for 115 and 230 kV buses.

Circuit breakers are taken out of service for routine maintenance, mechanical and other problems, relay system replacements, direction check of new relay systems, or direction check of old relay systems when new cables are pulled to the control room from the current or voltage transformers.

For many years, circuit breaker bypassing has presented a challenge for protection engineers. They have been asked to provide adequate protection for all the transmission lines and transformers terminated to a bus with a minimum number of solid state or electromechanical phase and ground relays. In general, it is not desirable to switch or modify the protection systems because the potential for error can result in loss of protection or misoperation.

The bus type shown in Figure 1c provides high flexibility for system operation. Any line can be operated from either bus. The buses can be operated together or independently, and either can be used as a transfer bus if a line CB is out of service. When any one of the bus CBs is out of service, the bus-tie breaker can be substituted, as shown in Figure 2. In this figure, breaker 2 is taken out of service and replaced with the bus-tie breaker using bus #1 as the transfer bus.

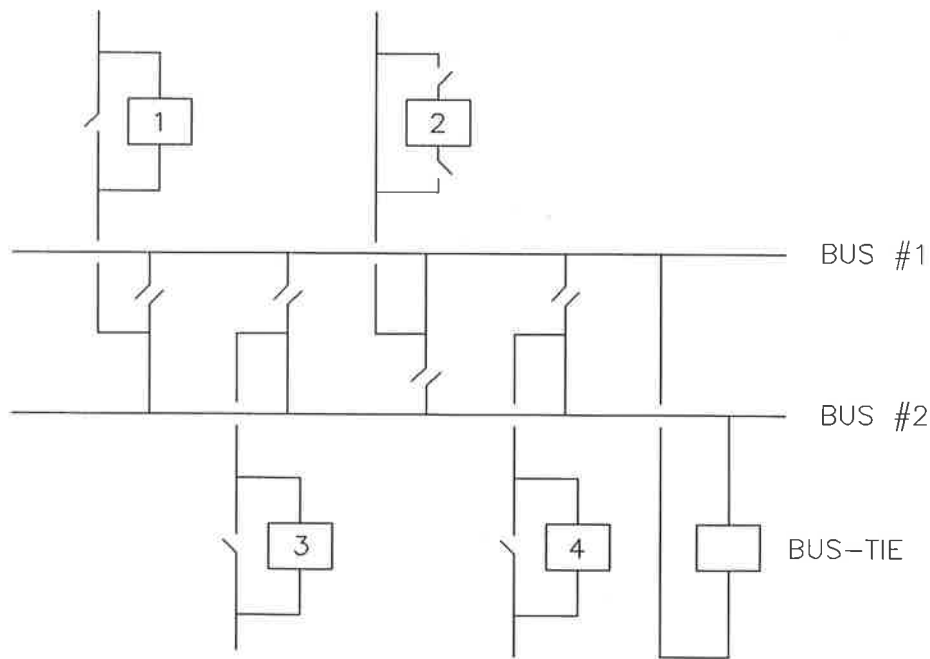

Figure 2: Bus-Tie Breaker used as Substitute for Line Breaker 2

During this time, the primary pilot and backup relay systems are taken out of service. The bus-tie breaker and its associated relay system provide protection for the line. The bus-tie breaker protection must be adaptable enough to provide protection for all the transmission lines or transformers connected to bus #1 and bus #2. Traditionally, this was accomplished with the complex design shown in Figure 3 (Figures 13,14, and 15 show the CT and PT switches in more detail). The objective was to provide different primary settings for each line or group of lines having approximately equal electrical parameters without making relay setting changes. Typical relays associated with the bus-tie breaker are zone packaged phase distance relays and a directional ground relay. The current transformer (CT) ratio selector switch was used to change CT ratios (CTR). Auxiliary autotransformers with a number of secondary taps and a voltage transformer selector switch provided different voltage transformer ratios (VTR). The various combinations of VTR and CTR could provide different primary reach for the phase distance relays of the bus-tie breaker. The current reversing switch was applied to provide flexibility in using bus #1 or bus #2 as the transfer bus, depending on operating preference.

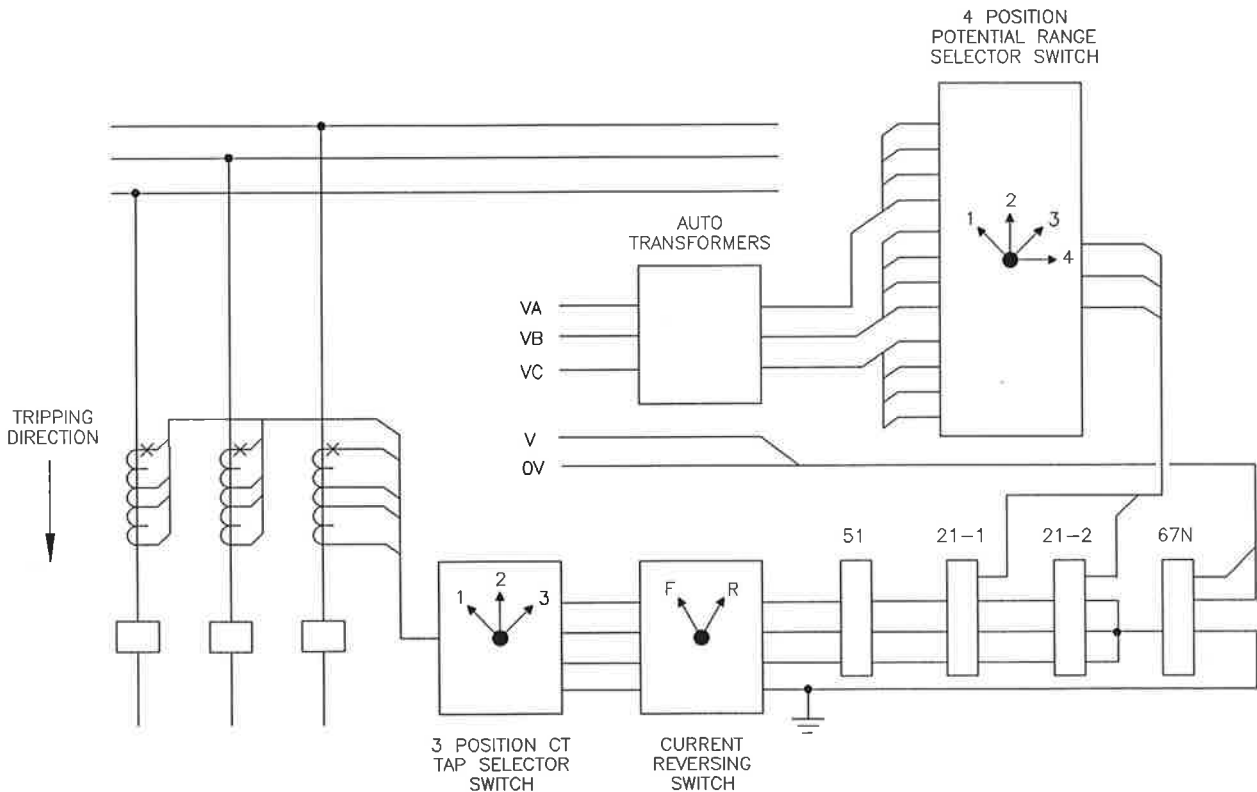

Figure 3: Traditional Bus-Tie Breaker Protection Scheme

Previously, design complexity and economic reasons prevented the protection engineer from providing a dedicated position for each line connected to the bus. Consequently, the number of positions were limited, forcing the engineer to group the lines depending on the similarity of their electrical parameters and make compromises in line protection while bypassing the CB. The following illustrate some of the compromises:

- The Zone 1 primary reach for each group was set less than the positive-sequence impedance of the shortest line in the group.
- The Zone 2 primary reach for each group was set greater than the highest apparent impedance of the lines in the group.
- The directional ground instantaneous was set higher than the maximum ground fault current contribution for faults at the remote buses of the lines in the group.
- The time overcurrent element of the directional ground relay was set to coordinate for all possible operating arrangements, an extremely difficult task.
- The auxiliary autotransformers provided reduced voltage to the phase distance relays which was not desirable.

One result was less instantaneous coverage for longer lines in the group. Another was longer tripping times for faults beyond the instantaneous reach of the phase distance and directional ground relay. This was due to coordination difficulties or overreaching of adjacent Zone 1 elements by the Zone 2 primary reach of the bus-tie CB.

The overall design was very complex and extremely expensive to test and maintain. During installation, direction checks were done for each combination of CTR and VTR positions to prove the proper direction of the bus-tie relays.

Some utilities make relay setting changes of the bus-tie relays before the bus-tie CB can be used as a substitute. This approach is very costly because it necessitates relay setting changes and relay testing each time, but fails to provide the flexibility desired by operating personnel.

BUS-TIE PROTECTION - NEW APPROACH

Several factors provide new solutions to an old problem: the introduction of digital relays for power system protection, the growing acceptance of these relays by utilities, and our ability to communicate with these devices from remote locations.

One option uses two digital relays for the bus-tie breaker, each one providing phase and ground protection as well as redundancy. The setting changes for each line can be accomplished with a script file and remote computer (see Figure 4). This approach presents some small problems, including additional training for operators and the fact that relays are not tested with the new settings.

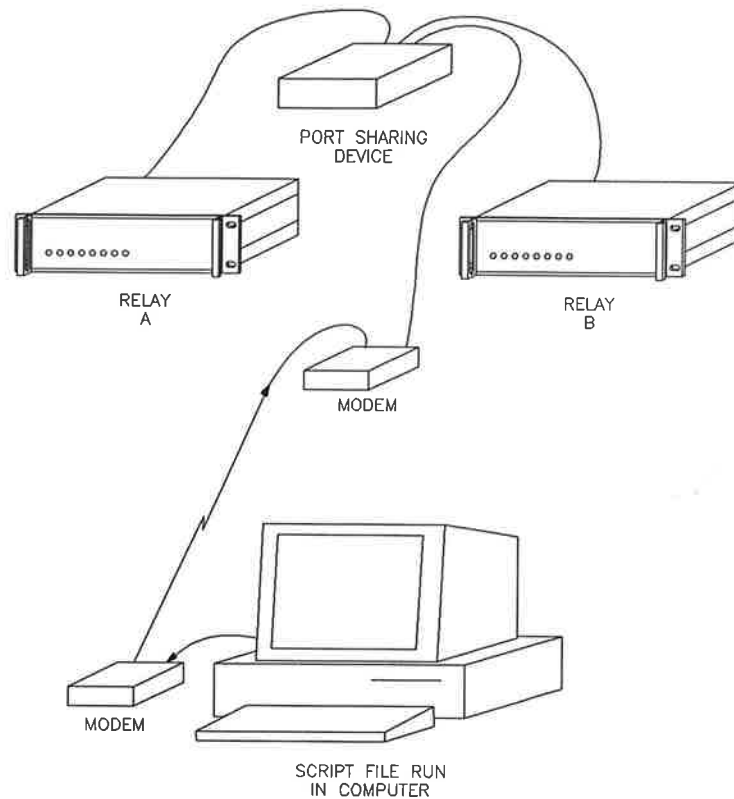

Figure 4: Setup for Changing Digital Relay Settings with a Script File and Remote Computer

Another option uses two digital relays with multiple setting groups and the ability to change settings locally with a position selector switch or remotely with a computer. PG&E selected this option for the reasons outlined below. Figure 5 depicts the new design.

- Each transmission line is protected by two backup relays with settings identical to the backup relay system that is out of service.
- The different relay settings can be activated with a line position selector switch. This approach is familiar to the operating personnel; no additional training is required. Switching centers will utilize the ability to change settings remotely, since the switching personnel have the necessary training in computers and remote communications.
- The new design does not require CTR or VTR changes. The wiring is simple, which makes the overall design both economical and easy to install, test, and maintain. The relays are tested only once; all group settings are made during installation.
- There is no need for a current reversal switch when only four lines leave a bus. A setting in the relay replaces the switch, allowing flexibility to use bus #1 or bus #2 as the transfer bus.

- The protection engineer need not calculate new relay settings if backup relays are the same as or similar to the relays used for the bus-tie breaker.
- CT transient performance improves because the new design does not require CTR changes which affect the CT "C" rating and digital relays present small CT burden.

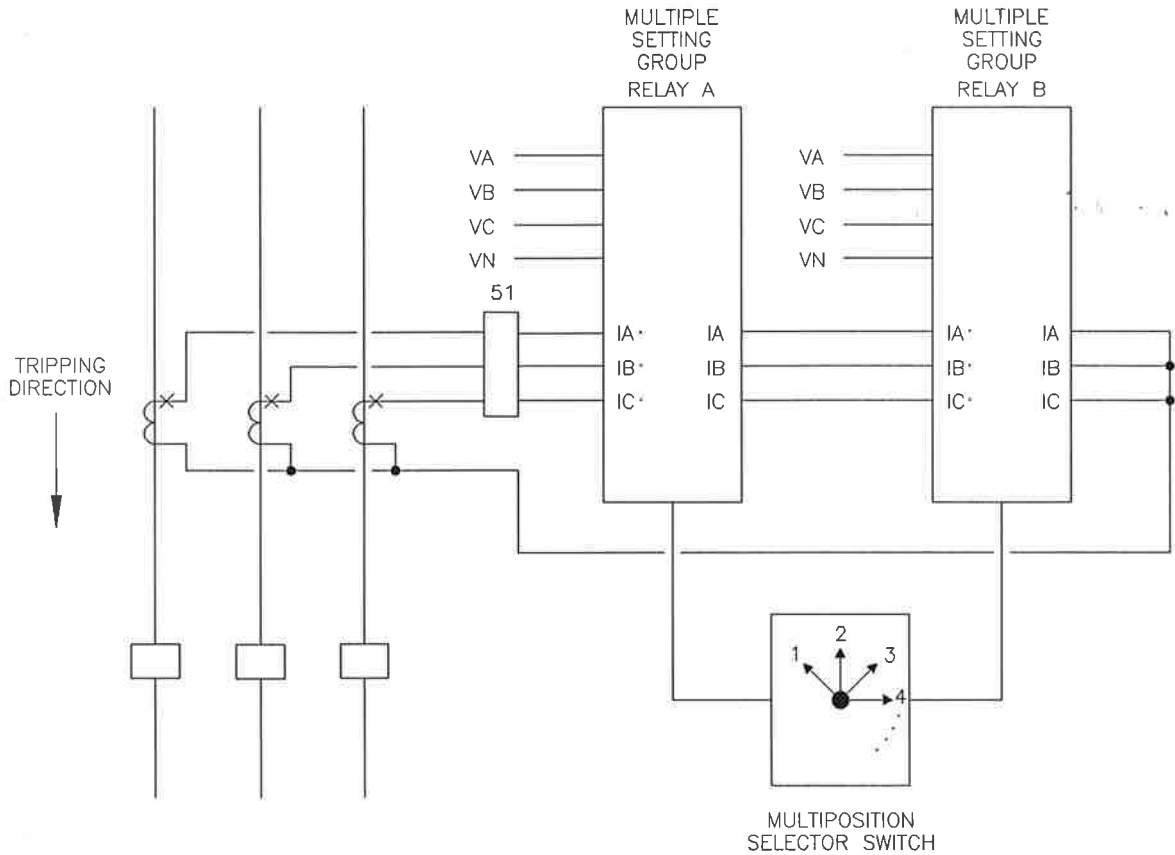

Figure 5: Bus-Tie Breaker Protection Scheme with Multiple Setting Group Relays and Selector Switch

RELAY OVERVIEW

A multiple setting group microprocessor-based relay can act as a replacement for many different relays with varied settings. It accomplishes this by storing eight different groups of settings in non-volatile memory, from which one setting group is enabled or activated. The substation operator can select which setting group to activate with a local selector switch, SCADA controlled selector switch, or by command from a terminal or computer.

The capability to reverse current transformer polarity via the CTP setting is a major cost saving feature of this relay. This capability eliminates the need for a costly external current reversing switch. In a bus-tie breaker application with four lines leaving the bus, the CTP setting can be used in place of a current reversing switch, allowing the relay to protect the lines from the main or transfer bus. The first and last four setting groups can be set identically with the exception of the CTP setting. In four setting groups, CTP can be set for protection using the main bus. In the remaining four, CTP can be set for protection using the transfer bus. The CTP setting can be used in a variety of other applications where there is a need to change the primary direction of protection.

The relay provides a secure and economical alternative to the traditional approach used for bus-tie breaker applications. Each setting group of the relay can be set to uniquely protect each line leaving the bus. This provides uniform protection for a line when a breaker is taken out of service. For example, the Zone 1 reach can be set to protect a short line in one setting group and a long line in another group. The relay eliminates the complex schemes and compromises used with single setting group relays to handle bus-tie breaker applications or other schemes where frequent setting changes are desired.

SETTING GROUP SELECTION SCHEME

A multiple setting group relay makes setting changes an easy task for operators or switchmen. Initially, the settings for each group can be set to provide protection for a variety of lines or situations. Setting groups may be selected by asserting input contact pairs of the relay locally with a selector switch, or remotely by keyboard command or SCADA.

This relay uses a secure scheme which dedicates five input contacts to insure that the correct setting group is activated at all times. As shown in Figure 6, a unique pair of these five input contacts is required to activate a setting group. Any other combination of these contacts causes the relay to close an alarm contact while the previously active setting group remains in service.

For example, if input contacts S3 and S4 are asserted, setting group three would be activated. Then if input contact S4 was lost due to a cut or disconnected wire or dc was lost to the input contacts, an alarm contact would assert and setting group three would remain active. This two of five selection scheme provides a secure way to select and maintain the correct setting group in the relay.

SETTING GROUPS INVOKED BY INPUT PAIRS

GROUPS	CONTACT INPUTS				
	S1	S2	S3	S4	S5
1	★	★			
2		★	★		
3			★	★	
4				★	★
5	★		★		
6		★		★	
7			★		★
8	★			★	
REMOTE		★			★

Figure 6: Setting Group Selection Through Input Contact Pairs

Figure 7(a) shows the use of a 2 deck multi-position switch to select between setting groups. When connected as shown, each position of this switch will assert an input contact pair that activates a unique setting group in the relay. Positions 1 through 8 are used to activate the relay's eight different setting groups. Position 9 of the switch activates the GROUP command in the relay. This command is used to select the active setting group from a terminal or computer and is enabled only if input contacts S2 and S5 are asserted. This eliminates the possibility of remotely selecting a setting group which differs from the one indicated by the selector switch.

Figure 7(b) shows a scheme using SCADA to select between the local selector switch or the GROUP command. SCADA output controls a switch which transfers dc between the selector switch and the input contacts S2 and S5, which enable the GROUP command. SCADA can also bump an automatic switch to change the active setting group.

SETTING GROUP SELECTOR SWITCH

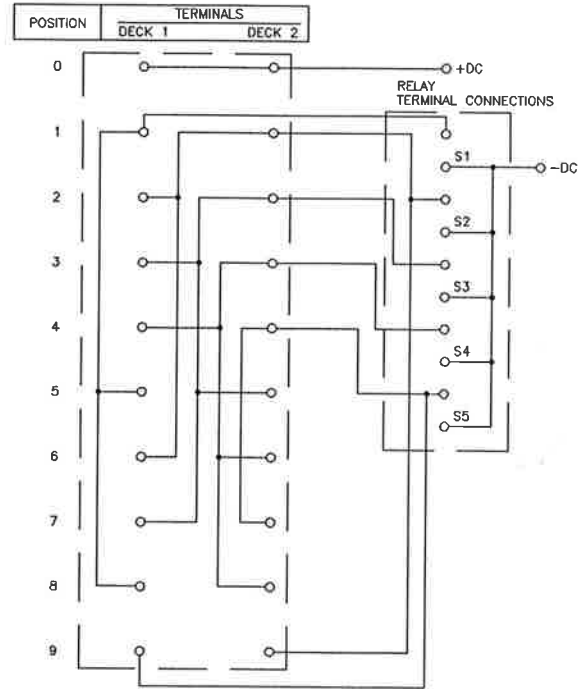

(a) Local Control with Selector Switch

SETTING GROUP SELECTOR SWITCH

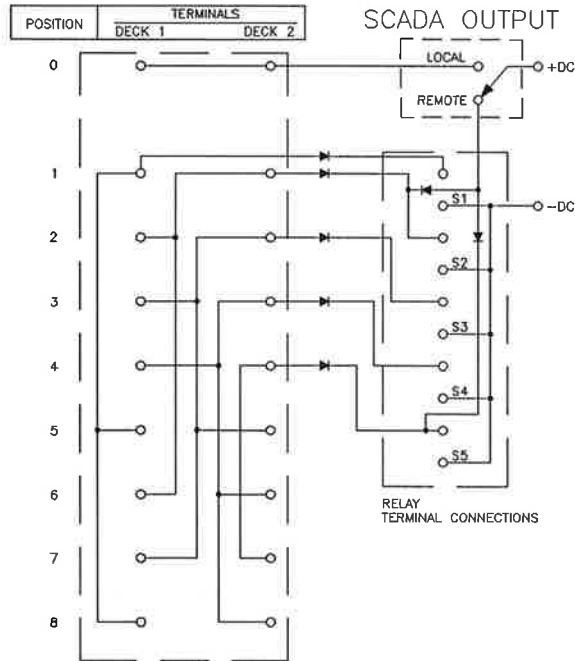

(b) SCADA Switches Between Local Control and Remote Control with Group Command

Figure 7: Selector Switch and Input Contact Connection Diagram

TESTING PHILOSOPHY

A multiple setting group relay allows for quick and secure setting changes. Each setting group can be initially set and tested to a company's specifications. After this, no further testing is needed. The relay provides security through the use of checksums (summation of bytes), eliminating the need to retest settings when the active setting group is changed. This makes setting changes easy and fast, without risking loss of security.

When group settings are set or changed, the relay calculates a checksum to go along with the setting group. The checksum is stored in non-volatile memory, which the relay retains when power is lost. The checksum for each group is periodically recalculated using settings stored in the EEPROM. The new checksum is compared to the original checksum. If they do not agree, the relay is disabled, an alarm contact closed, and a setting failure indicated in the relay status report. This process ensures that relay settings remain the same as when initially set and tested.

TYPICAL APPLICATIONS

A digital relay with multiple setting groups can be applied widely in other system configurations. Figure 8 shows one such application. Here, when a breaker at the looped station is out for maintenance, the station by-pass switch is closed. This maintains power transfer between the remote buses and creates a three terminal line. The pilot relay systems of the transmission lines are removed from service during this time, and existing backup relay systems cannot provide adequate protection. The previous choices were to make relay setting changes of the backup relay systems or provide additional relays to place in service only during breaker maintenance at the looped station. Today, a digital relay with multiple setting groups is applied as the backup relay system. Two setting groups are utilized, one under normal conditions and the other while the looped station is bypassed. This application provides superior phase and ground protection.

Figure 9 shows a system configuration where a digital relay with multiple setting groups has been applied as a backup relay system. In this application, the cable protection is comprised of two primary pilot relay systems and a backup third level relay system. With the addition of the two reactors (one at each bus) and the requirement that protection work with all switching arrangements, it was possible to provide adequate protection with two setting groups. One group is used when the reactor at San Mateo bus and the 230 kV cable are in service; the other is used when both reactors and the 230 kV cable are in service.

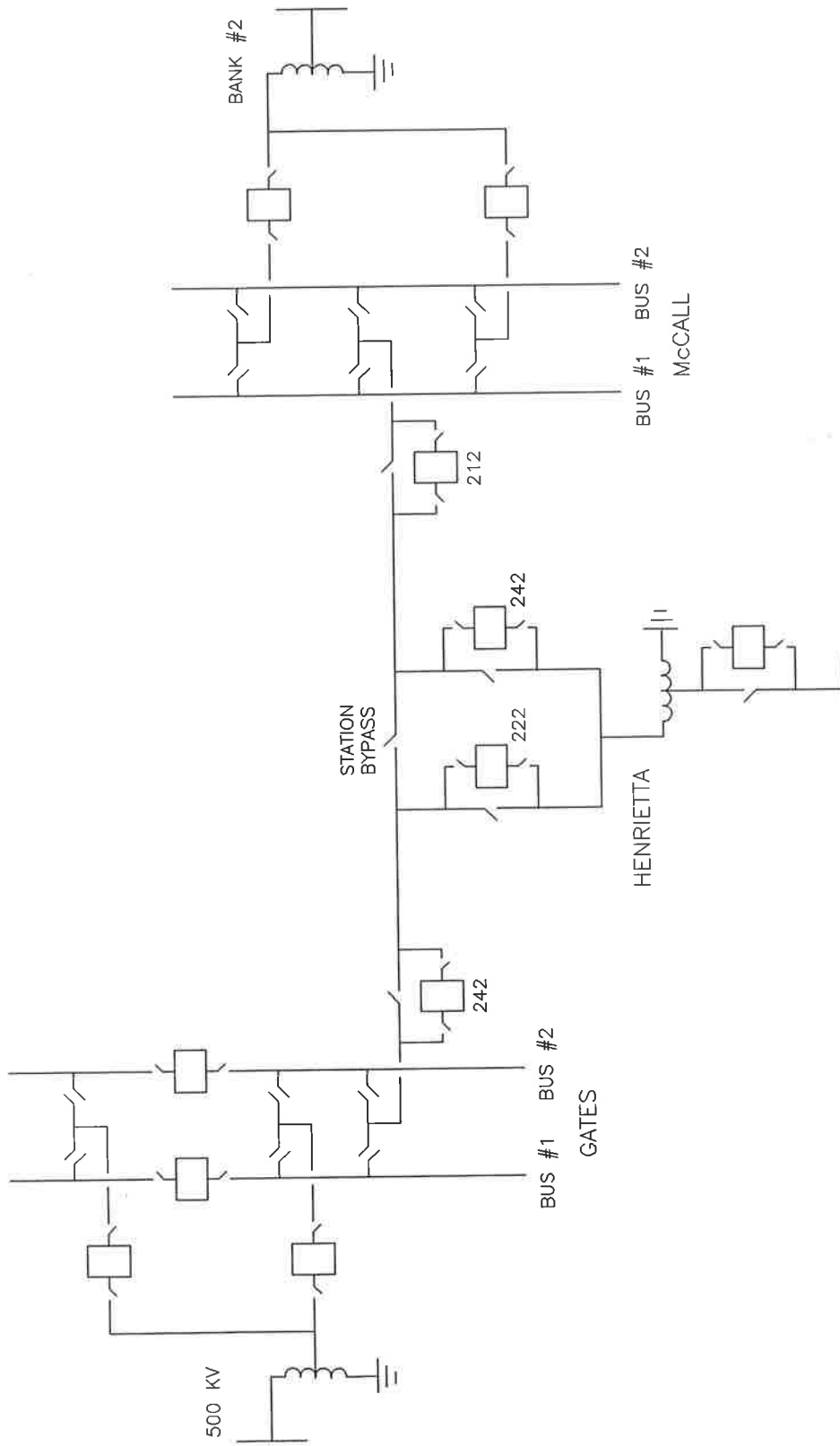

Figure 8: Looped Station By-Pass Single Line Diagram

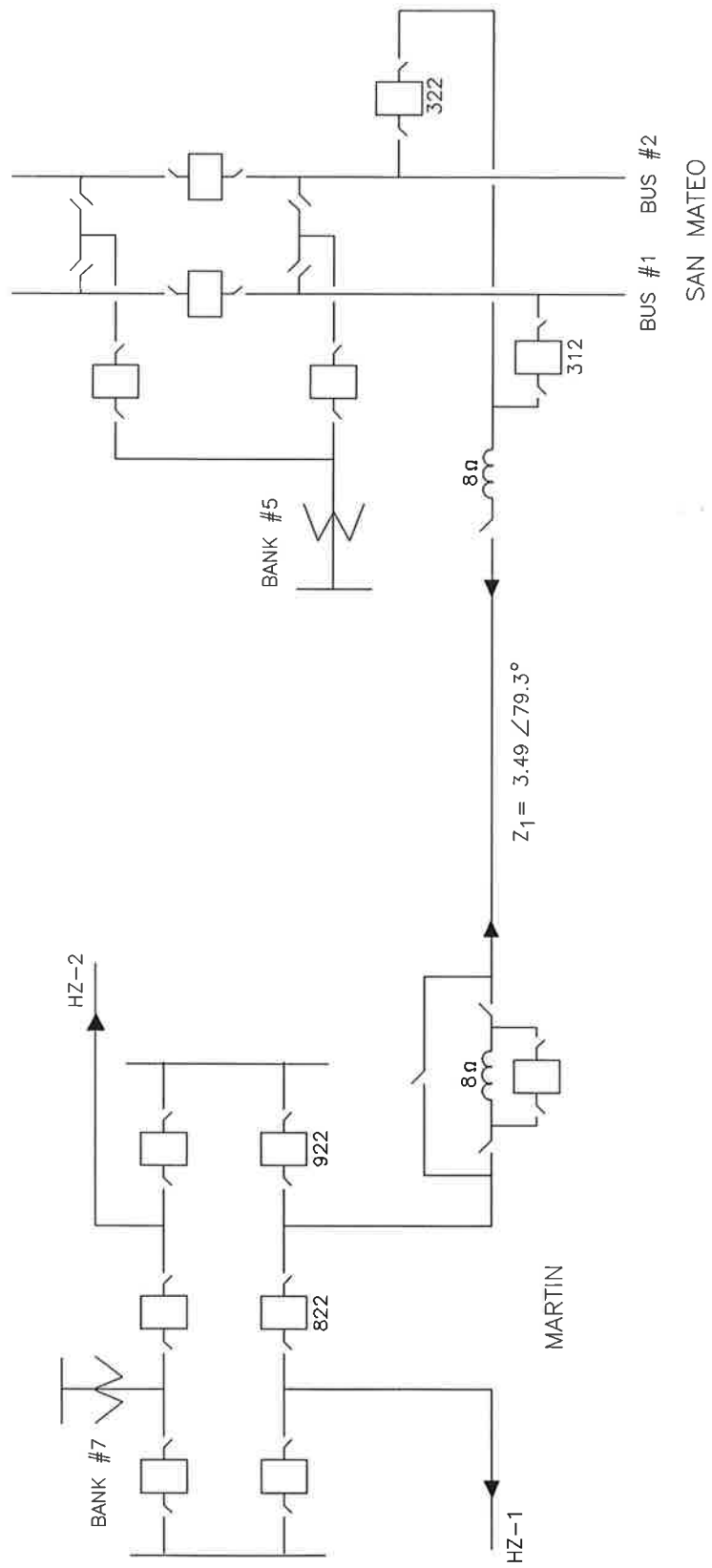

Figure 9: Series Reactor By-Pass Application Single Line Diagram

Figure 10 shows a system configuration where a transformer is tapped off a 115 kV transmission line. A circuit switcher is utilized on the high side of the transformer. At some time intervals, it is necessary to disengage the motor and observe its functionality without interrupting service to the station. During this time, the transformer protection is disabled, and it becomes necessary to provide protection from the remote stations or one remote station feeding the transformer radially. A digital relay with multiple settings can be applied at the remote stations to provide protection during this time.

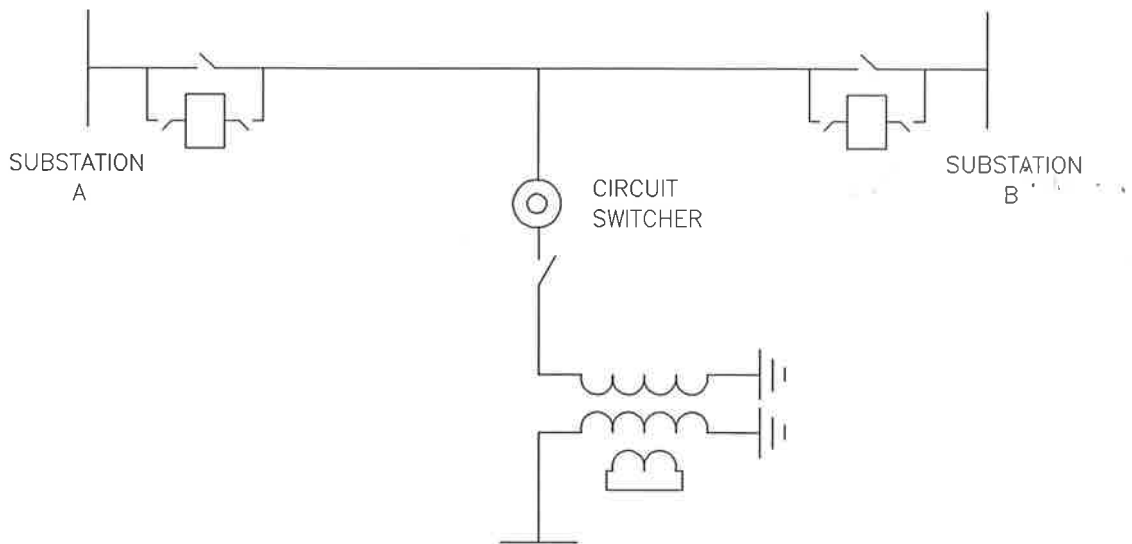

Figure 10: Tapped Station, Circuit Switcher Decoupled

Other applications include system configurations where known changes in zero-sequence sources take place, and on mutually coupled parallel transmission lines when one line is out of service and grounded at both ends. The list of applications will grow as protection engineers are exposed to this type of relay and its capabilities.

CONCLUSION

We have introduced a variety of applications where a digital relay with multiple setting groups helps the protection engineer overcome the shortcomings and compromises of traditional electromechanical methods.

This new type of relay simplifies design, testing, and operation of bus-tie breaker applications and other line protection schemes requiring routine or emergency setting changes. The ability to tailor a group of settings for each line position provides improved protection. In addition, the self testing capability of the relay upgrades the reliability of the entire scheme.

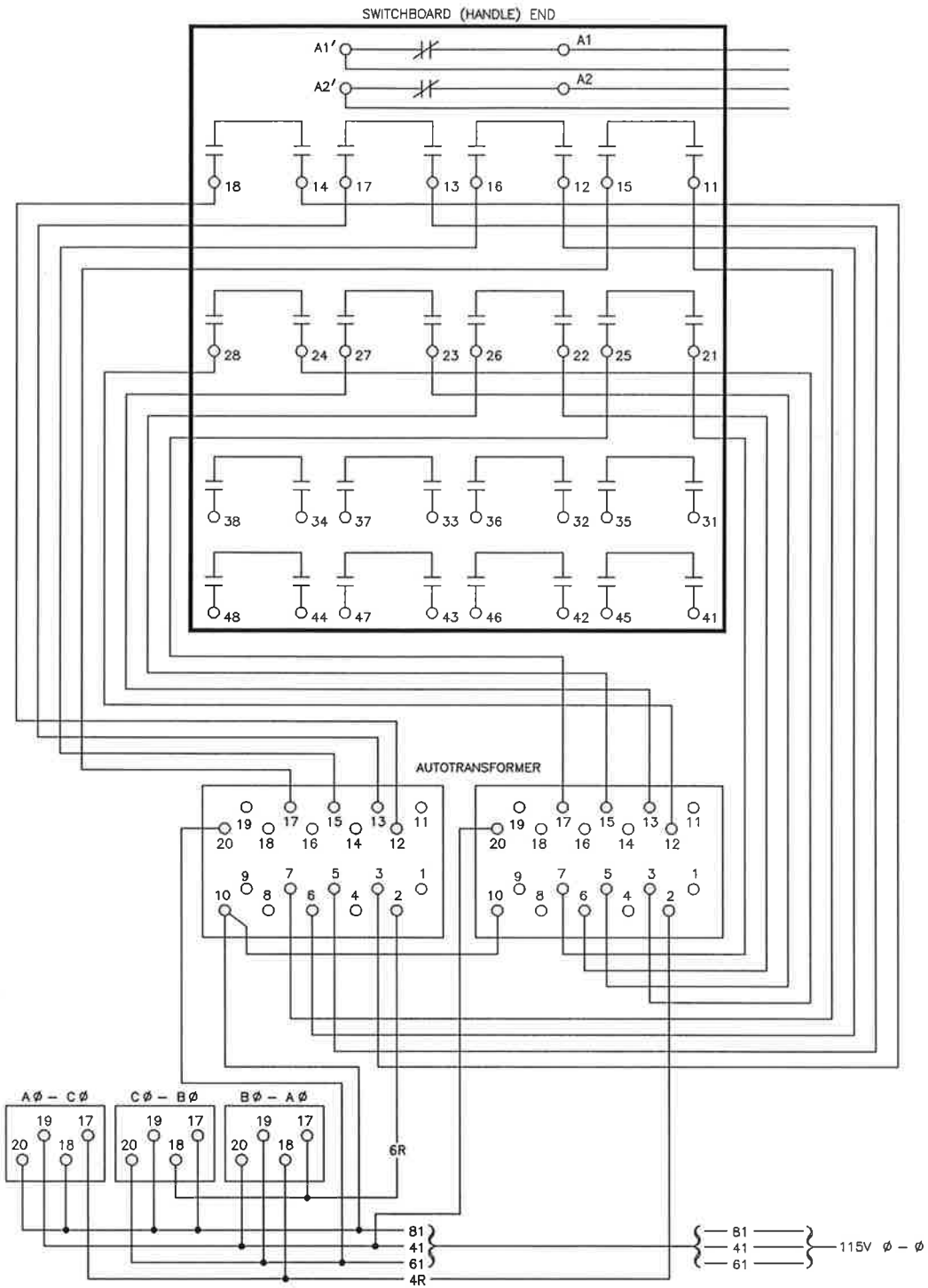

Figure 11: Secondary Autotransformer Connection Diagram Eliminated by New Scheme

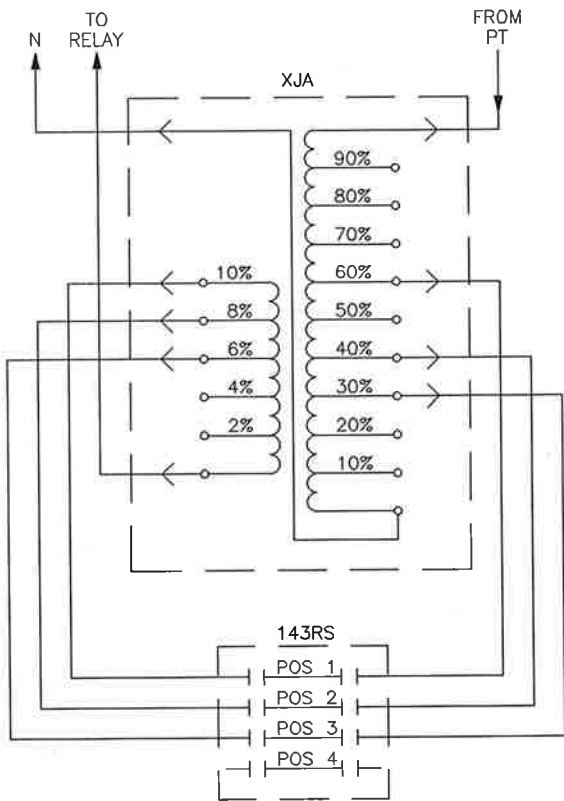

Figure 12: Secondary Potential Autotransformer and Potential Range Selector Switch Eliminated by New Scheme

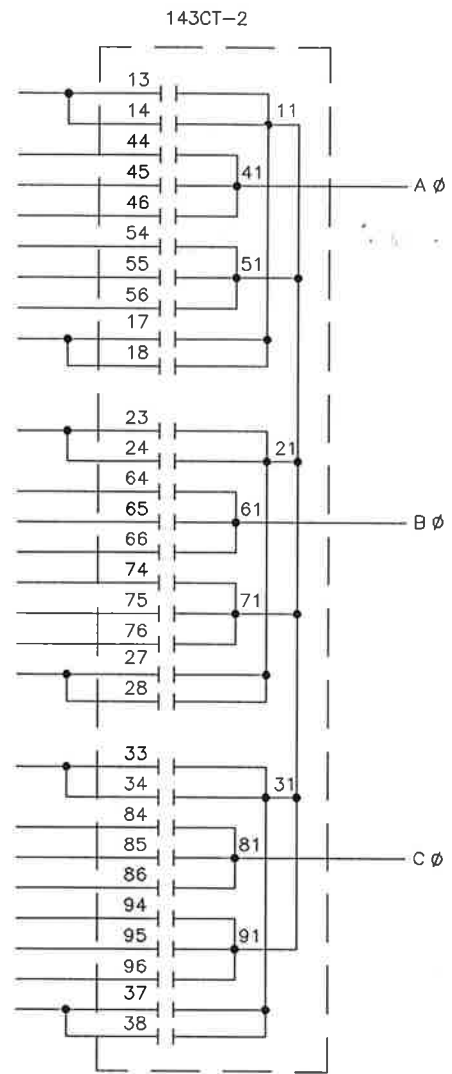

Figure 13: CT Ratio Selector Switch Eliminated by New Scheme

Copyright © SEL, 1990
(All rights reserved)
Printed in USA

Rev. 1