

Measuring and Improving the Switching Capacity of Metallic Contacts

Tony Lee and Edmund O. Schweitzer, III
Schweitzer Engineering Laboratories, Inc.

Presented at the
54th Annual Georgia Tech Protective Relaying Conference
Atlanta, Georgia
May 3–5, 2000

Previously presented at the
53rd Annual Conference for Protective Relay Engineers, April 2000

Originally presented at the
26th Annual Western Protective Relay Conference, October 1999

MEASURING AND IMPROVING THE SWITCHING CAPACITY OF METALLIC CONTACTS

Tony Lee
Edmund O. Schweitzer III, Ph.D.
Schweitzer Engineering Laboratories
Pullman, WA USA

INTRODUCTION

Metallic contacts are nearly ideal when they are either open or closed. While open, even a very small contact can withstand several thousand volts transverse without breaking down. While closed, even a very large contact has less than milliohms of contact resistance. However, when metallic contacts make or interrupt load current, they are far from ideal. This paper discusses the make and interrupt process of metallic contacts. We concentrate on contacts suitable for use as output contacts in a modern protective relay, but much of the discussion can be extended to any metallic contact. We investigate the root cause of switching related failures, and propose solutions to some common but misunderstood problems.

MAKE CAPACITY OF CONTACTS

The contact shown in Figure 1 is a reed relay intended to energize contact inputs on high speed communications gear. We chose reed relays because of their speed, and because of the seemingly limited switching requirements of the application. However, we became aware that several of these contacts were welding shut, even though the contact input circuit should have limited the switched current to well below the rating of the contact. More investigation showed that the contact input circuit had surge suppressor capacitors connected from each side of the circuit to earth ground, as shown in Figure 1.

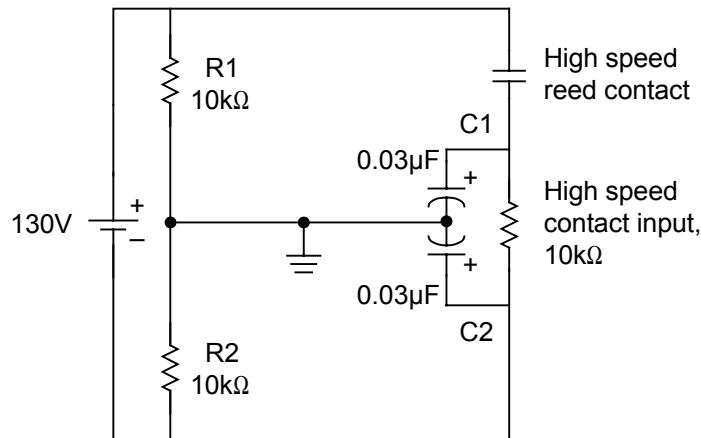

Figure 1: High Speed Reed Contact Switching a High Speed Contact Input

When the contact in Figure 1 is open, there is no current flowing through the contact input circuit, so both sides of the contact input circuit are at -65 volts with respect to earth. Since both sides of the contact input are at the same potential, both surge capacitors, C1 and C2, are charged to -65 volts. After the contact has been closed for some time, C1 is charged to +65 volts, and C2 remains charged at -65 volts.

When the contact closes, a current spike flows through C1 and C2, charging C1 from -65 to 0 volts and C2 from -65 to -130 volts. The current spike is limited in magnitude only by connection, wiring, contact and battery resistance and inductance. After some time, C2 discharges through R2 and returns to a charge of -65 volts and C1 charges through R1 to +65 volts. We hypothesized that this current spike was responsible for welding the contacts of the reed relay.

To test our hypothesis, we constructed the circuit of Figure 1, and operated the contact. The contact welded shut after four operations. We then replaced the contact and placed 200 ohms in series with the new contact. The reed contact operated 1000 times without a failure. Next, we increased C1 and C2 from 0.03 microfarads to 0.3 microfarads, and finally to 3 microfarads. The reed contact operated another 1000 times without a failure.

The analysis below better demonstrates the failure mechanism. The circuit shown in Figure 2 is equivalent to the circuit in Figure 1 with respect to the contact. R_C is the resistance associated with the contact, and R_E is the lumped resistance of the remainder of the circuit due to connections, wiring, etc. R_S is the shunt resistance of the intended load. We expect that R_S is large compared to $R_C + R_E$, so R_S does not play an important part in limiting the initial current spike. We ignore R_S in the following analysis.

Contacts are damaged by excessive temperature. Excessive temperatures are generated when a contact absorbs too much energy. Energy (E) is the time integral of power (P).

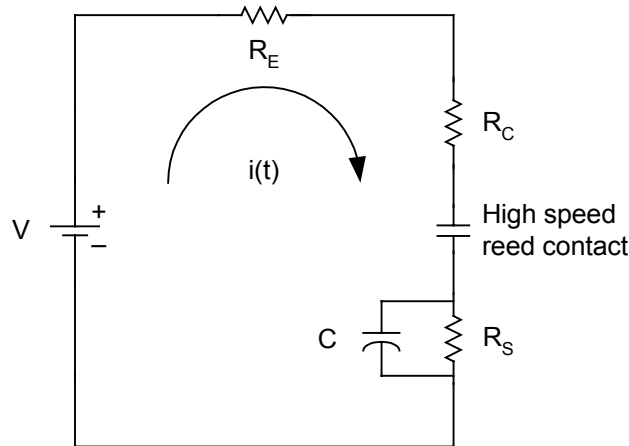

Figure 2: Equivalent Circuit to Figure 1.

We want to calculate how much energy the contact resistance R_C absorbs. The current which flows after the contact closes is given by:

$$i(t) = \frac{V}{R_L} e^{\frac{-t}{R_L \cdot C}} \tag{Equation 1}$$

Where $R_L = R_C + R_E$.

The instantaneous power dissipated by R_C is

$$p(t) = i^2(t) \cdot R_C$$

and the energy dissipated by R_C is the time integral of power, or

$$E = \int_0^{\infty} p(t)dt = R_C \int_0^{\infty} i^2(t)dt$$

Substituting $i(t)$ from Equation 1 above and integrating gives

$$E = \frac{R_C}{R_L} \cdot \frac{1}{2} CV^2 = \frac{R_C}{R_C + R_E} \cdot \frac{1}{2} CV^2 \quad \text{Equation 2}$$

The energy $\frac{1}{2}CV^2$ is eventually stored on the capacitor. So Equation 2 tells us that the energy dissipated by the contact is some fraction of the energy that is eventually stored on the capacitor. The fraction is the ratio of the contact resistance to the total circuit resistance. For example, if we make the total circuit resistance 100 times the contact resistance, one percent of the capacitive energy is absorbed by the contacts.

Notice that the analysis and the result would have been the same if we were discharging the capacitor from V to zero volts through the contact, because the equation for the current flowing through the contact would be the same as Equation 1.

We can rearrange Equation 2 as

$$E = \frac{R_C V}{R_L} \cdot \frac{1}{2} CV = I_{PK} \cdot R_C \cdot \frac{1}{2} CV$$

Where I_{PK} is the peak value of $i(t)$ by Equation 1.

This shows that contact damage is proportional to peak current. So if we are given some open circuit voltage V , load shunt capacitance C , and a contact with resistance R_C , the only recourse we have to reduce contact damage is to reduce I_{PK} . Inserting a 200 ohm resistor in series with the small contact, and near the small contact, eliminates the problem with no unwanted side effects.

INTERRUPTING CAPACITY OF CONTACTS

Throughout the remainder of this paper, we investigate the interrupting capacity of a protective relay contact output. The contact is rated by the manufacturer to interrupt no more than 0.4 amps inductive with a source voltage of 125 volts. At the end of this paper, we show how the same contact can interrupt over 100 amps of inductive load driven by a source voltage as high as 250 Vdc. The techniques applied in this paper are applicable to any metallic contact used to switch dc loads.

Interrupting Resistive Loads

Figure 3 shows a test circuit we used to investigate the interrupting capacity of our protective relay contact output with a purely resistive load. Figure 4 shows the voltage developed across the contact on Channel 1 (V1 in Figure 3) and the current flowing through the contact on Channel 2 (V2 in Figure 3) when the contacts open during a resistive interrupt.

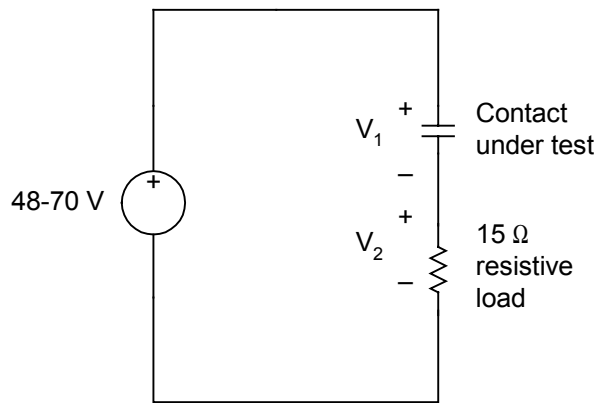

Figure 3: Resistive Load Interrupt Test Circuit

Early in Figure 4, the contact is closed, the contact voltage is near zero, and the contact current is limited to about 3.2 amps by the 15 ohm load resistor and the 48 V power supply. The instant the contacts part, contact voltage increases to about 12 V, and the current decreases by 12 V / 15 ohms, or 0.8 amps, to 2.4 amps. In fact, throughout Figure 4, each increase in contact voltage has a corresponding decrease in contact current, as expected for a purely resistive load.

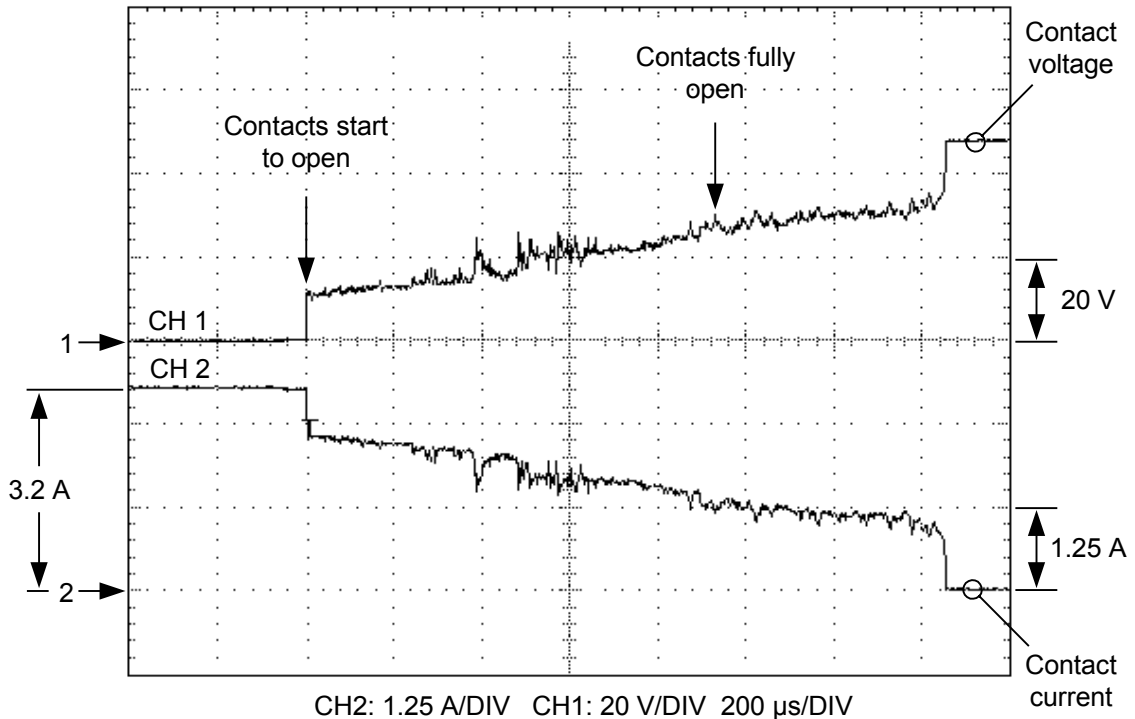

Figure 4: Contact Voltage and Current During Interruption of a Resistive Load

For this particular contact arrangement, the contacts reach full separation in about 900 microseconds, or about 4.5 horizontal divisions after the contacts first part in Figure 4. The increasing contact voltage from first separation to full separation may be attributed to an increasing contact gap as the contacts travel away from each other. However, during the final 600 microseconds after the contacts have reached full separation, the contact voltage continues to increase as the current continues to decrease. This shows an important characteristic of the electric arc, negative resistance [3]. Lower arc currents produce higher arc voltages.

The contact voltage continues to increase until it abruptly jumps to the open circuit voltage of about 48 V. At the same time the current abruptly decreases to zero. Apparently, at a current of about 1 amp, the conduction characteristic of the arc changes from a relatively low voltage to a higher voltage. This drives the current to zero, and ends the electrical arc. We discuss this change in the conduction characteristic again later when we discuss interrupting inductive loads.

Even if the arc is eventually interrupted, the arcing process can substantially degrade the contact faces. Contacts are damaged by the high temperatures that occur when the contacts absorb too much energy. Energy is the product of power and time; power is the product of current and voltage. We can easily calculate the energy created by the electrical arc in Figure 4. The current averages about 1.7 amps, and the voltage averages about 22 volts, each for about 1.44 milliseconds.

$$1.7 \text{ A} \bullet 22 \text{ V} \bullet 1.44 \text{ ms} = 0.05 \text{ J}$$

We expect that the damage done to the contacts is proportional to this energy. We use this number as a comparative reference later.

To understand why the electrical arc formed in the first place, we concentrate on the instant the contacts first parted. Figure 5 zooms in on the abrupt increase in contact voltage at the time the contacts first part. That figure again shows the voltage developed across the contact on Channel 1, and the current flowing through the contact on Channel 2. Note the change in time scale and Channel 1 gain from the previous figure. Contact voltage is now shown at one-half volt per division, and the sweep rate has been increased from 200 microseconds to 20 microseconds per division.

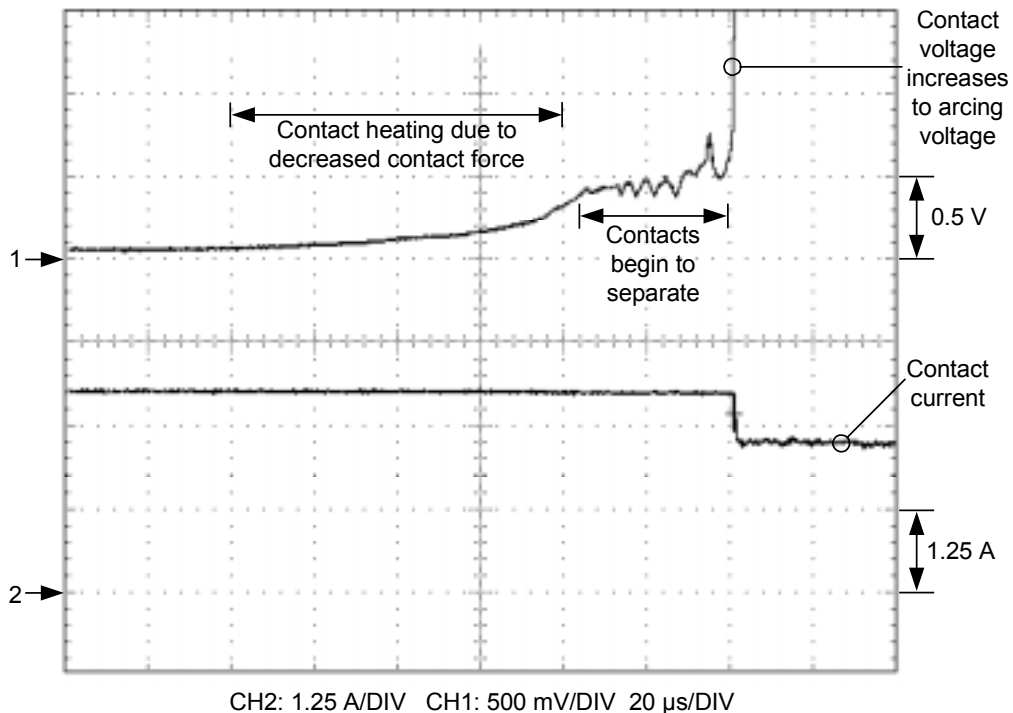

Figure 5: Contact Voltage and Current as the Contacts Part While Interrupting a Resistive Load

Just before the contacts part, several problems develop. First, the contact force decreases, which causes the contact resistance to increase. Load current flowing through this increased contact resistance heats the contacts. This increase in contact resistance creates an increased contact

voltage, which we see in Figure 5, from about 40 to 120 microseconds. Notice that during this time, the contact current remains constant, so the increase in contact voltage can only be caused by an increase in contact resistance.

Next, some portions of the contact faces separate, while other portions remain in contact. This crowds load current into the few remaining places where the contacts still touch and, again, causes the temperature at those spots to increase. This crowding effect is shown in Figure 5, from about 120 to 160 microseconds. Just before the contacts finally part, the last point of contact on the contact faces often boils, and can even vaporize because the load current is crowded into a small area on the contact face. As the contacts continue to part, they can leave molten and vaporized metal in their wake, contaminating the intercontact gap.

When the contacts finally part, the contact gap is small and contaminated by molten and vaporized metal, and the contact faces are hot. These are the perfect conditions for an electrical arc.

If an electrical arc does ignite, it may not be extinguished for several tens of milliseconds, or even seconds, if ever. If the electrical arc is not extinguished, then the contacts are destroyed, and the load is not deenergized and may also be destroyed. At a minimum, some protective device, such as a panel fuse, is forced to operate. Such a case is shown in Figure 6. Notice that the sweep rate has been decreased to 10 milliseconds per division.

In Figure 6 the source voltage is 56 V, which increases the load current to 3.7 amps. The contact failed to interrupt the load, and the contacts were eventually destroyed. Compare Figure 6 to the successful interruption shown in Figure 4. In Figure 4 after the current had decreased to about 1 amp, the arc conduction characteristic changed, and the current abruptly decreased to zero. In Figure 6 the current stabilizes at about 1.7 amps, and the conduction characteristic does not change. Apparently this change in conduction characteristic is necessary to interrupt the load current in this circuit. Without it, the load current is not interrupted. We discuss the change in the arc conduction characteristic in more detail later in this paper.

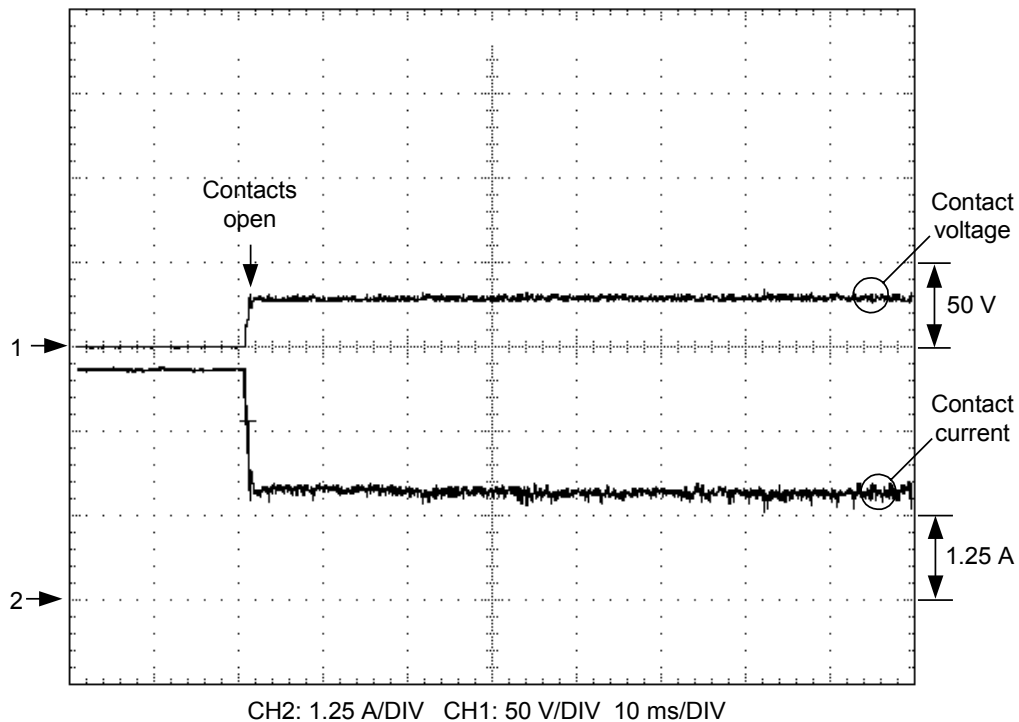

Figure 6: Failure to Interrupt a Resistive Load

Interrupting Inductive Loads

Bare Contacts

Next we change the load from purely resistive to a combination of resistance and inductance. Figure 7 shows the circuit connections.

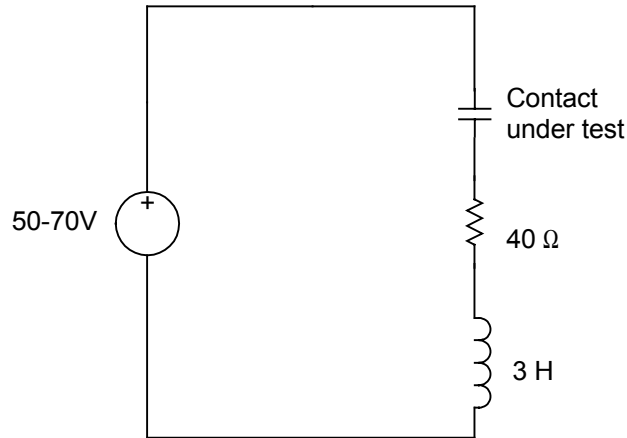

Figure 7: Inductive Load Interrupt Test Circuit

The contact voltage and current are shown in Figure 8. Notice the scale changes in Figure 8. The sweep rate is now 10 milliseconds per division, and the contact voltage on Channel 1 is at 100 volts per division. Peak current is limited to about 1.4 amps by the circuit resistance of 40 ohms and the source voltage of 57 volts. When the contacts part, the contact voltage jumps from near zero to around 30 volts.

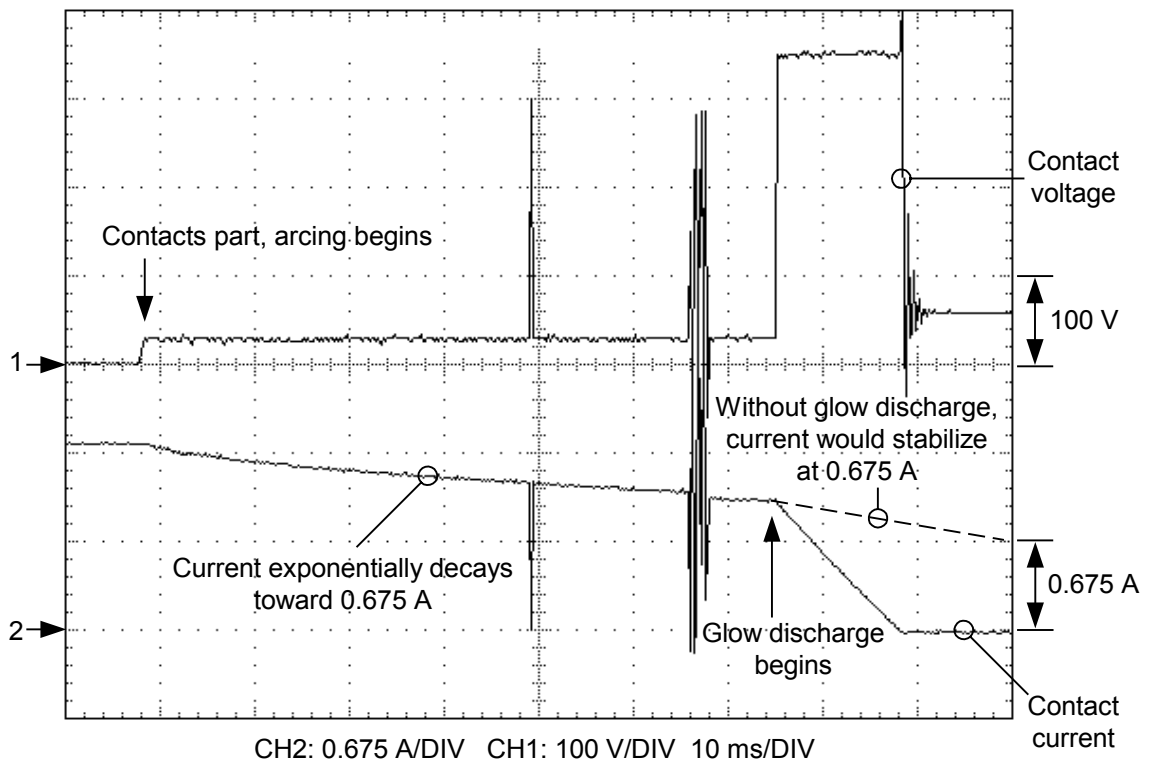

Figure 8: Contact Voltage and Current During a 1.4 Amp Inductive Interrupt

Even though the contact voltage increases 30 volts, the contact current does not immediately decrease as in the resistive case. Instead the current decreases gradually from 1.4 amps toward a new steady state value of:

$$\frac{(57 \text{ V} - 30 \text{ V})}{40 \Omega} = 0.675 \text{ A}$$

The rate at which the current decreases is determined by the circuit time constant, which for this case is:

$$\frac{3 \text{ H}}{40 \Omega} = 75 \text{ ms}$$

This analysis generally agrees with the waveforms shown in Figure 8 for the first 65 milliseconds of the interruption. However, as the current decreases through about 1 amp, the voltage across the contact increases from around 30 volts to around 350 volts due to some high voltage conduction phenomenon. Since the contact then supports 350 volts and, at the instant the conduction characteristic changes, the circuit resistances support about $1 \text{ A} \cdot 40 \Omega$ or 40 volts, the inductor supports about:

$$57 \text{ V} - 40 \text{ V} - 350 \text{ V} = -333 \text{ V}.$$

The high negative voltage across the inductor should result in a nearly linear decrease in current at a rate of about:

$$\frac{333 \text{ V}}{3 \text{ H}} = 111 \text{ A/s}$$

or, on the time scale of Figure 8, about 1.1 amps per 10 milliseconds. This actually occurs in the plot of Figure 8.

As discussed in Reference [1], we suggest that the high voltage conduction phenomenon is glow discharge, as described in Reference [2]. Had glow discharge not occurred, the current would have apparently stabilized at around 0.675 amps, and would not have been interrupted.

We can test that theory by increasing the source voltage until the steady state arcing current is above 1 amp, which should prevent glow discharge from occurring. With an arcing voltage of 30 volts, the current will stabilize at 1 amp if the source voltage is increased to 70 volts.

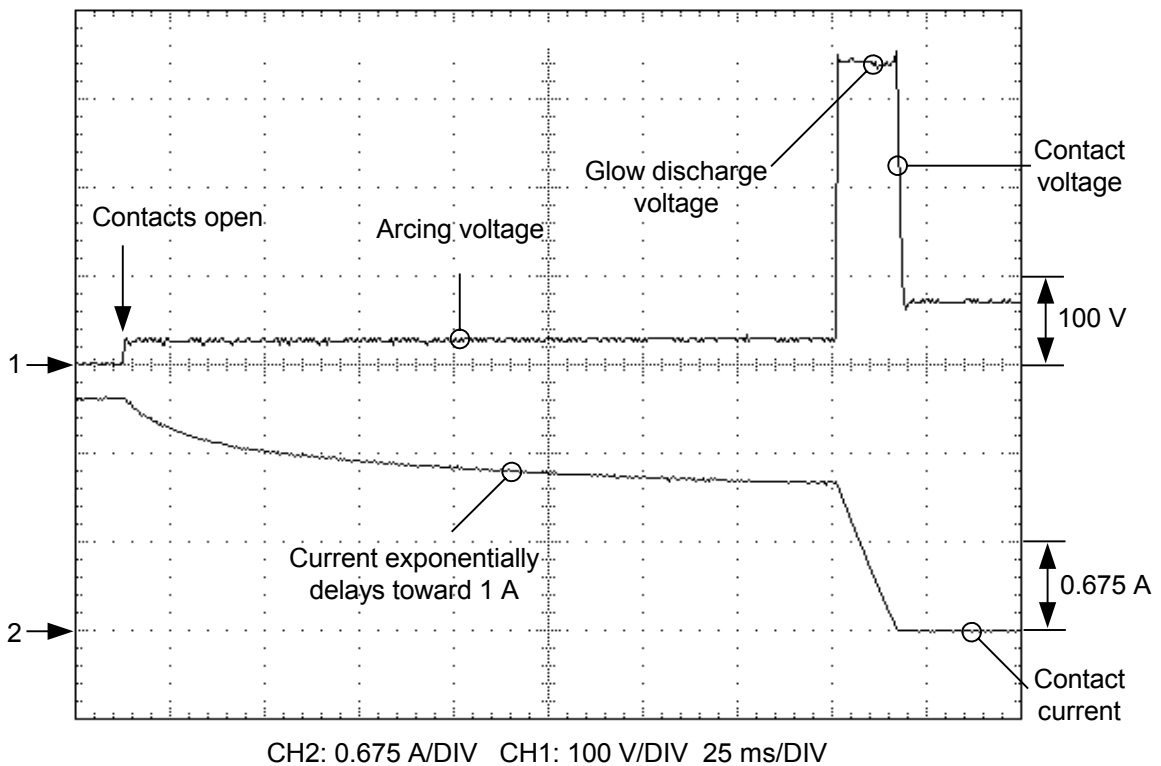

Figure 9: Contact Voltage and Current During a 1.7 Amp Inductive Interrupt

Figure 9 shows the case when the source voltage is increased to 70 volts. The arcing current asymptotically approaches about 1 amp, and only after nearly 190 milliseconds does glow discharge begin. It appears that without glow discharge the current would have stabilized at some non-zero value, and the contacts would have been destroyed.

Figure 10 shows the case when the source voltage is increased to 72 volts. The current stabilizes at just above 1 amp, and glow discharge does not occur even after 750 milliseconds. In fact, the current was not interrupted, and the contacts were destroyed in this case.

Referring back to Figure 9 where the current was successfully interrupted, we can approximate the energy dissipated by the contacts. The arcing portion averaged about 30 volts across the contacts and about 1.3 amps for about 190 milliseconds, for a total of 7.4 Joules. The glow discharge presented the contacts with 350 volts and an average of about 0.53 amps for 17.5 milliseconds or about 3.2 Joules. Therefore, the total energy in the arc and glow discharge for this case was 10.6 Joules. Even though the current was about half of the resistive case considered previously, the inductive load generated more than 200 times as much arcing energy.

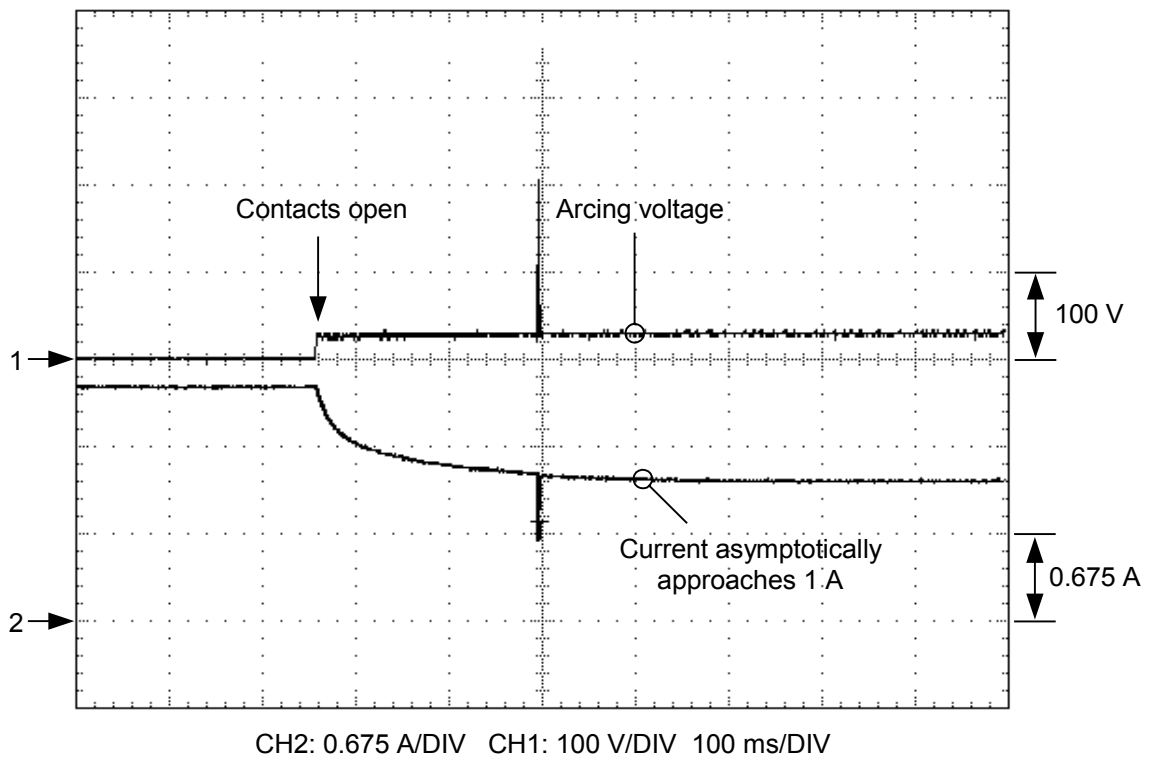

Figure 10: Contact Voltage and Current During a Failed Interruption of 1.8 Amps Inductive

Contact Protected by a Flyback Diode

To reduce the energy dissipated by the contacts during an inductive interrupt, we should first recognize an important difference between the inductive and resistive cases: the inductive load stores energy that must eventually be dissipated. We can try to dissipate that inductive energy entirely in the circuit resistances by using a flyback diode, as shown in Figure 11.

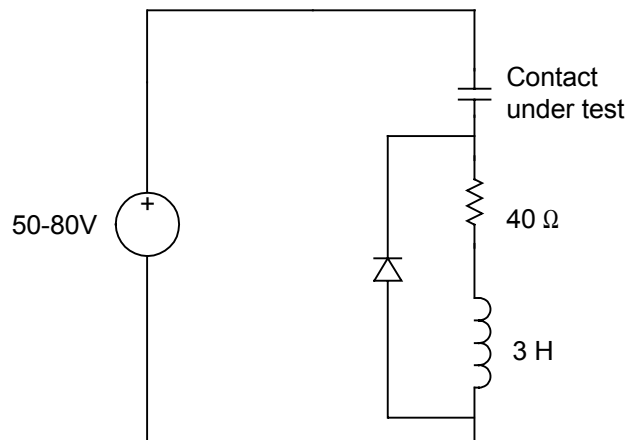

Figure 11: Inductive Interrupt Test Circuit With Flyback Diode

For the contact to make use of the flyback diode, the contact voltage must still increase from near zero to just higher than the source voltage to forward bias the diode. Then the inductive current can circulate through the diode. Figure 12 shows the resulting contact current and voltage.

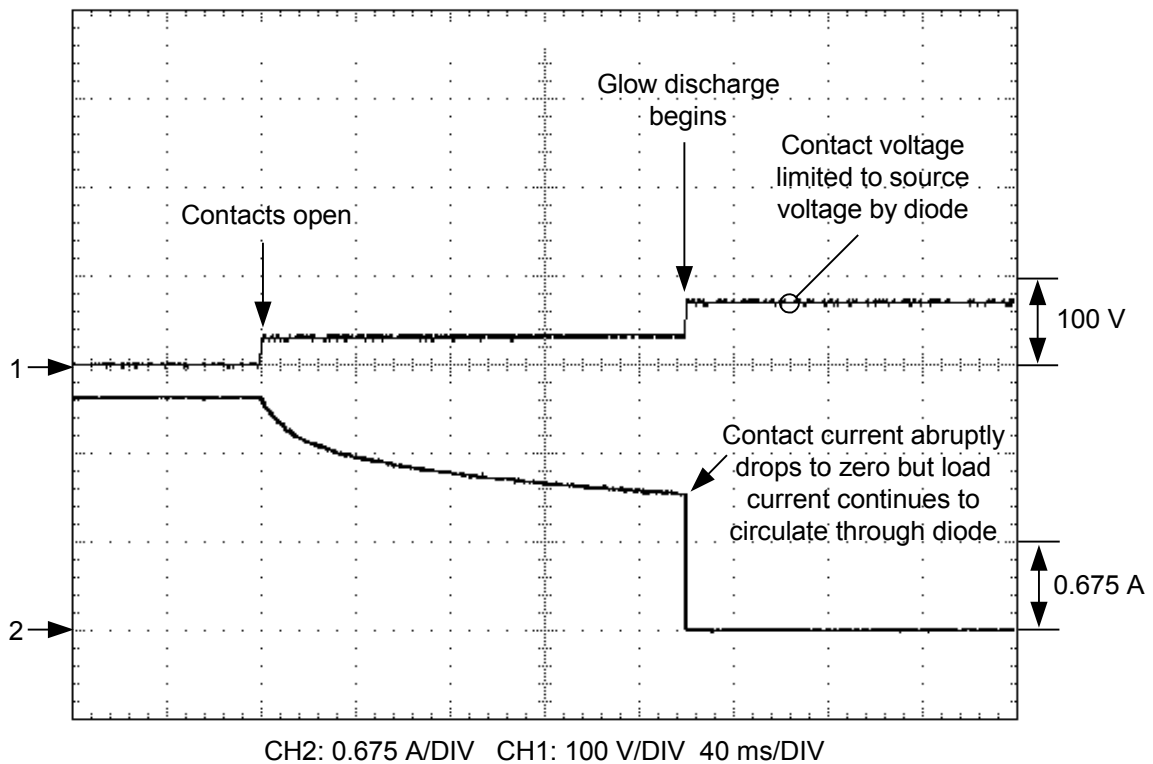

Figure 12: Contact Voltage and Current for Circuit in Figure 11

An electrical arc still forms. This is not surprising, since our circuit analysis shows that the flyback diode will not conduct until the contact voltage exceeds the supply voltage. Because the 30 volts developed by electrical arcing is well below the supply voltage, the contact still arcs. However, when the arc current drops below about 1.1 amps, the contact can no longer sustain an arc. It must transition to glow discharge. As we have seen, glow discharge produces a contact voltage of around 350 volts, enough to forward bias the flyback diode. As soon as the flyback diode conducts, the contact current abruptly drops to zero and glow discharge ceases. However, the load is not interrupted until current ceases to circulate through the flyback diode. The duration of that circulation is dependent on the inductor time constant.

Since glow discharge only occurred very briefly, the energy created by glow discharge is near zero. The total energy dissipated is reduced by perhaps thirty percent, using the totals from the previous inductive interrupt case.

Contact Protected by a Varistor

In some instances a flyback diode is not permissible, either because of a perceived reliability problem, or because it delays the actual interruption of load current by allowing current to continue to circulate for some time. In those cases, we can clamp the voltage across the contact to less than the glow discharge voltage by connecting a non-linear device such as a Metal Oxide Varistor, or MOV, across the contacts. For example, an MOV with a clamping voltage of about 250 volts clamps the contact voltage below the glow discharge voltage. In that case, the MOV dissipates all the energy previously dissipated in the contacts during glow discharge. The contacts still dissipate the same energy during arcing. This is the same situation as with a flyback diode, but with the added benefit of protecting the contact from transient overvoltages.

Even though less energy is liberated during the arcing process with the flyback diode or MOV, we have not significantly increased the switching capacity of the contact. The contact arcing

voltage must still be sufficient to drive the circuit current low enough that glow discharge can begin. If it does not, then the current is not interrupted, and the contacts are destroyed. In other words, the flyback diode or MOV may increase the lifetime of the contact when switching loads within the contact rating, but they do not extend the contact rating.

Another problem with relying on glow discharge to help interrupt loads is that glow discharge may not occur at all with some contacts. The authors have only witnessed glow discharge with relatively small contacts, such as those used in modern protective relays. When a contact with significantly more gap was used, no glow discharge was observed.

Contact Protected by a Shunt Capacitor

We wish to prevent the initial electrical arc from forming, and we do not want to rely on glow discharge as even part of the interruption process. It seems that if we could limit the contact voltage to less than the arcing voltage, then an electrical arc could not develop. Conceptually, we could accomplish this by placing a capacitor across the contacts as shown in Figure 13.

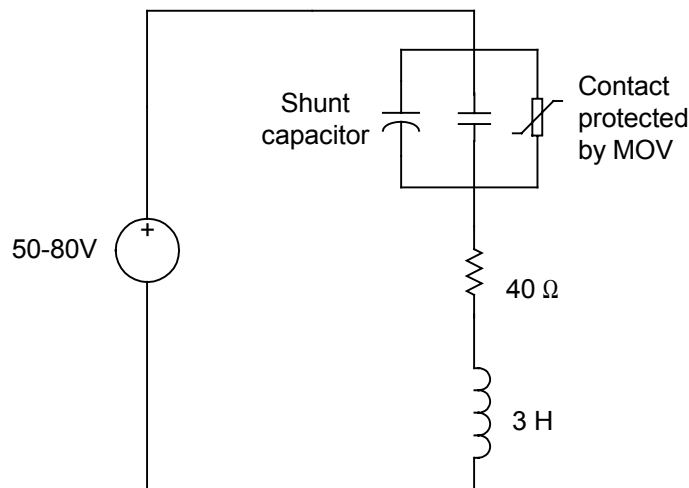

Figure 13: Inductive Interrupt Test Circuit With a Snubber Capacitor

When the contacts part, load current begins to charge the capacitor. If the rate of rise of voltage across the capacitor is sufficiently low (if the capacitor is sufficiently large) then the parting contacts hold off this increasing voltage without flashing over. The circuits considered so far are capable of interrupting about 1.75 amps inductive, but with some arcing. Let us next calculate the shunt capacitance necessary to interrupt 1.75 amps inductive without arcing.

The contacts we have been using separate totally in about 1 millisecond. When fully open the contact can withstand about 3000 volts. Assuming a constant separation rate, this suggests that the withstand voltage increases at about 3 volts per microsecond when the contacts are parting. Therefore, the shunt capacitor must limit the contact voltage rate-of-rise to less than 3 million volts per second while being charged with 1.75 amps.

$$i = C \, dv/dt \, , \text{ so}$$

$$C = \frac{i}{(dv/dt)} = \frac{1.75 \text{ A}}{(3 \text{ MV/s})} = 0.6 \, \mu\text{F}$$

To find the peak voltage reached by the capacitor, equate the energy stored in the load inductor to the energy eventually stored on the capacitor:

$$\frac{1}{2}LI^2 = \frac{1}{2}CV^2 \text{ so}$$

$$V = I\sqrt{\frac{L}{C}}$$

Where V is the peak voltage reached by the capacitor, I is the load current flowing before the contact opens, L is the load inductance, and C is the value of the shunt capacitor.

Substituting 3 H, 0.6 μF, and 1.75 amps, gives:

$$V = 3.9 \text{ kV}$$

Clearly, we need to limit the voltage rise across the capacitor. We did so by placing an MOV across both the contact and the capacitor. Fortunately, many protective relay contacts are protected by an MOV. The MOV in this case limits the voltage across the contacts to about 450 volts.

To test this theory, we constructed the circuit of Figure 13. Figure 14 shows the contact voltage and current during a 1.75 amp inductive interrupt. No arcing was observed. The capacitor charges very rapidly to the MOV clamping voltage. The MOV clamps at about 450 volts which forces about -450 volts across the inductor. This high, negative voltage causes inductor current to ramp down nearly linearly to zero.

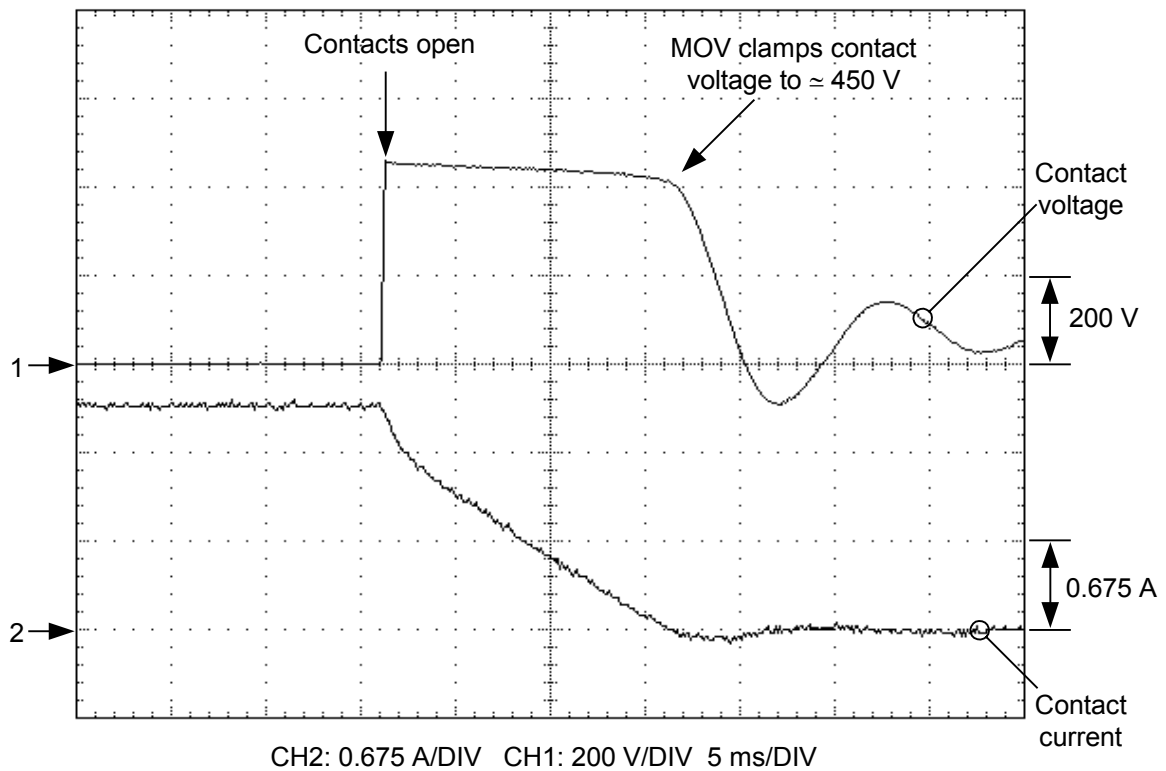

Figure 14: Contact Voltage and Current During a 1.75 Amp Inductive Interrupt With 0.6 μF Shunt Capacitor

Figure 15 zooms in on the moment the contacts part. Again, no arcing is evident. The load current charges the capacitor at very nearly the predicted three million volts per second, until it reaches the MOV clamping voltage.

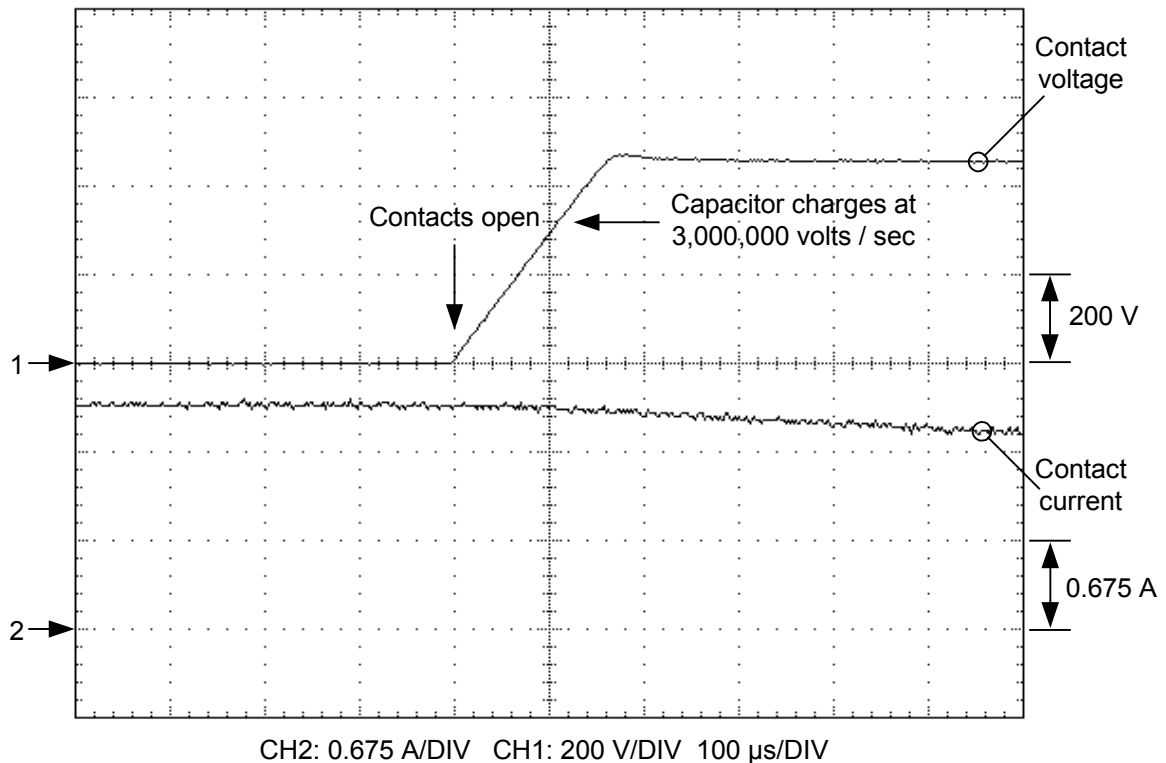

Figure 15: Contact Voltage and Current During a 1.75 Amp Inductive Interrupt With 0.6 µF Shunt Capacitor

Theoretically, this approach is scalable to much larger currents. However, as the capacitor value increases, it becomes more likely to cause problems in dc control circuits. As seen in the first section of this paper, the capacitor can cause damage to the contacts when the contacts close. When the circuit is first energized, perhaps by closing a cutout switch or a panel circuit breaker, the capacitor allows current to flow around the open contact for some time. Depending on the load, this may not be acceptable. Finally, at high frequencies, such as those often seen in typical dc control circuits during switching operations, the capacitor can appear as a short circuit.

The Hybrid Contact

We wish to place a device across the contacts that prevents the contact voltage from increasing to the arcing voltage until the contacts have parted sufficiently, but which does not damage the contacts when they close, and which does not appear as a short circuit to high frequencies.

Reference [1] describes one such circuit which uses a power transistor to shunt current around the parting contacts. The transistor is controlled with a signal that must be timed to coincide with contact separation. When that circuit is used in a protective relay, the signal must also pass across an isolation barrier to maintain safety isolation. The circuit shown below is another approach and is described more fully in U.S. Patent 5,652,688.

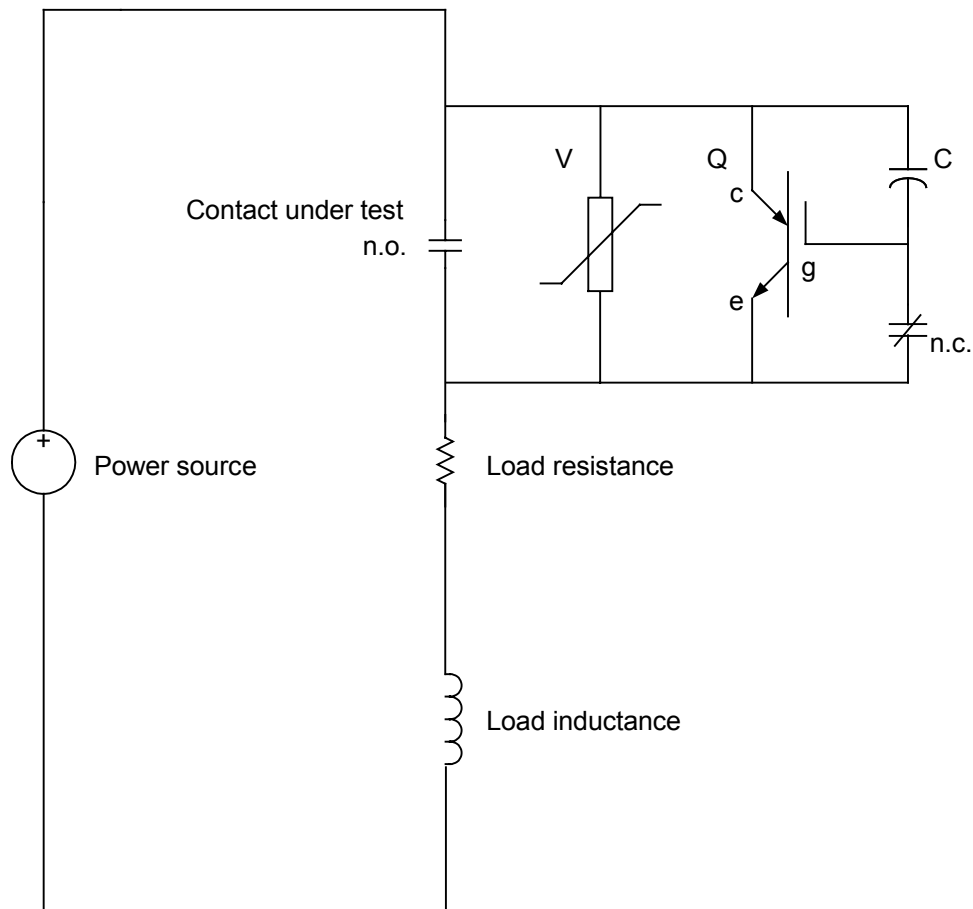

Figure 16: Hybrid Contact: a Parallel Connection of Solid State and Metallic Contacts

In Figure 16, load current turns on the transistor and the contact being protected provides timing to turn off the transistor. Hence, the transistor control signal does not cross the isolation barrier (which is expensive and complex to do), and the timing is automatically matched to the contact being protected.

The contact under consideration is a form C. We use the normally open contact to switch load current. When the normally open contacts part, load current is forced to flow through capacitor C and into gate g of transistor Q. Q begins to conduct when its gate is charged to about 6 volts. It takes about 5 nC to charge the gate of Q to 6 volts. That charge passes through capacitor C, and also charges C. The voltage across the normally open contacts is the sum of the gate voltage of Q and the voltage across C. Therefore, we wish to limit the voltage generated across C when it passes charge to the gate of Q. We chose a value of 2.2 nF for C. This generates $5\text{nC} / 2.2\text{nF} = 2.3$ volts across C, and a total of 2.3 volts + 6 volts or 8.3 volts across the parting contacts.

For currents that produce an arcing voltage greater than 8.3 volts, the normally open contacts will never arc. Instead, transistor Q turns on and conducts when the normally open contacts part, and the contact voltage is clamped at about 8.3 volts. When the contacts have separated completely, the normally closed contact closes, and discharges the gate of transistor Q. This turns off Q, which forces the load current to flow through the Metal Oxide Varistor V. The MOV is selected to generate about 370 V when current passes through it. This generates about -370 V across the inductor, and forces the load current to zero.

When the normally open contact is open, the normally closed contact shorts the transistor gate to the emitter, so the transistor is held solidly off. It cannot be turned on until the contact is closed

again. The 2.2 nF capacitor does not pass sufficient charge during circuit energization to pickup even the most sensitive load.

We first tested this circuit with the 1.75 amp inductive load described earlier. Figure 16 shows the resulting voltage and current. The contact voltage is clamped at about 370 V. This high voltage forces the inductive load current toward zero.

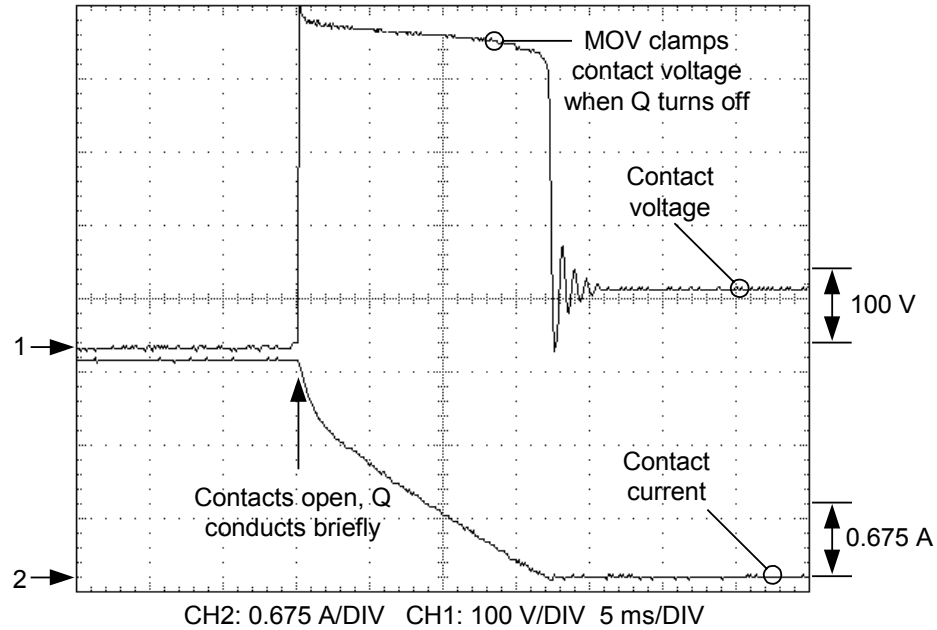

Figure 17: Contact Voltage and Current During a 1.7 Amp Inductive Interrupt

Figure 17 shows the entire interruption process. Figure 18 zooms in on the instant that the contacts part.

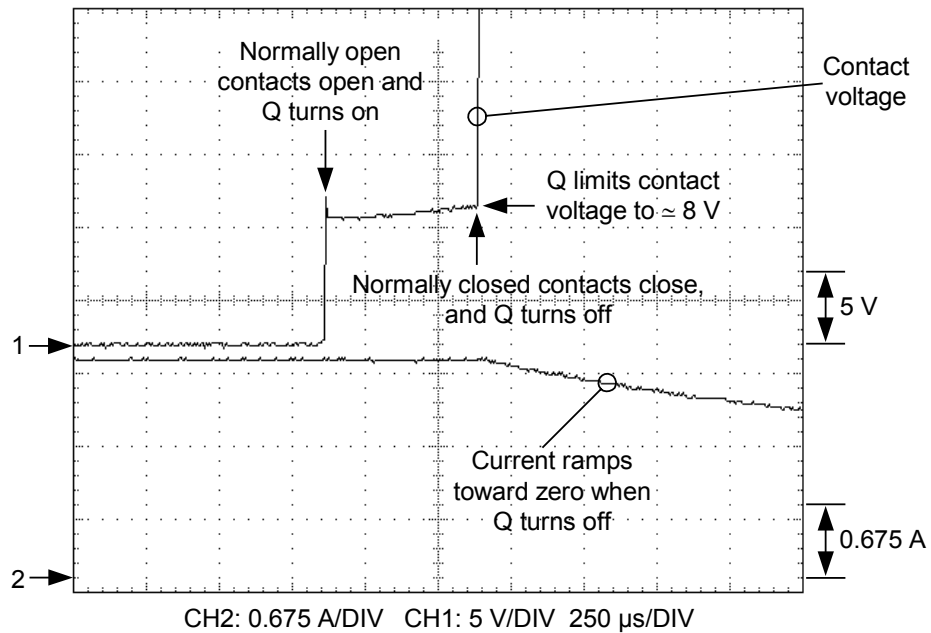

Figure 18: Contact Voltage and Current as the Contacts Part During a 1.75 Amp Inductive Interrupt

In Figure 18, the contact voltage increases abruptly from near zero to 8 volts when the contacts part. Power transistor Q then turns on and clamps the contact voltage at about 8 volts. After 500 microseconds, the normally closed contacts close, which turns Q off. Load current is then forced to flow through the MOV, which causes the contact voltage to increase rapidly, and forces the current to begin to ramp toward zero.

We then tested the circuit shown in Figure 16 at 9 amps and at 21 amps. Figure 19 and Figure 20 show the resulting waveforms, again zoomed in to the region where the contacts first part.

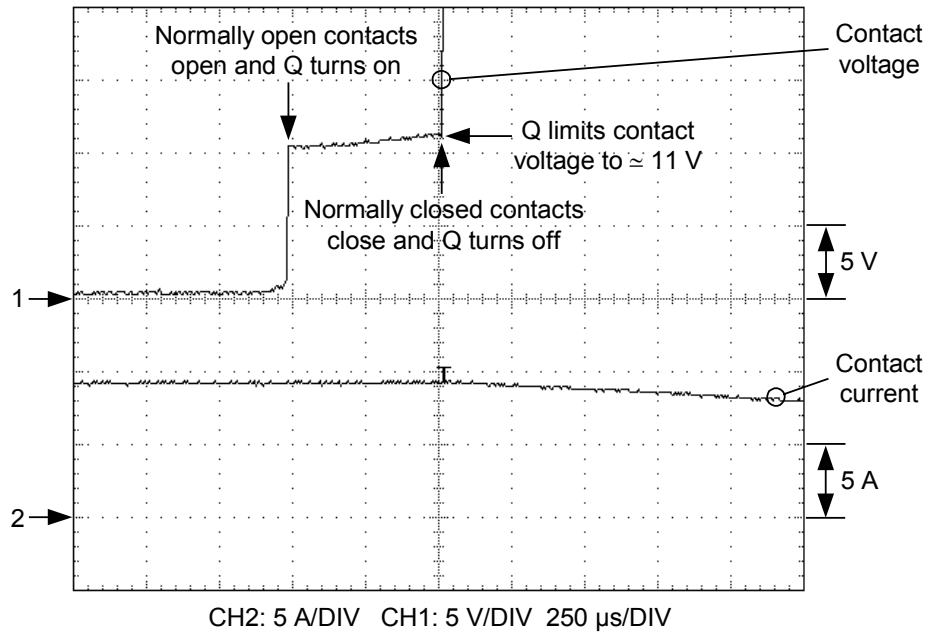

Figure 19: Contact Voltage and Current as the Contacts Part During a 9 Amp Inductive Interrupt

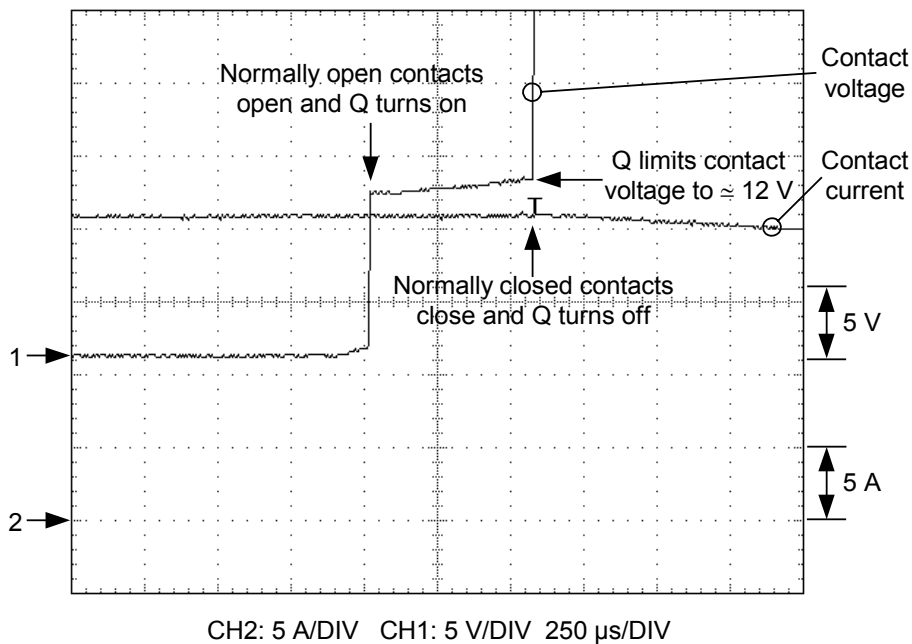

Figure 20: Contact Voltage and Current as the Contacts Part During a 21 Amp Inductive Interrupt

Note that these interruptions resulted in essentially zero energy dissipated in the contacts, because no arcing occurred. The sum of the energy contained in the inductive load and delivered by the power supply is dissipated in the MOV and the load resistance. Therefore, the contacts exhibit very little wear. We have used this circuit to interrupt a 10 amp inductive load at 125 Vdc 10,000 times without sustaining visible damage to the contacts.

This circuit arrangement is limited by the negative resistance characteristic of the electric arc and the positive resistance characteristic of transistor Q in Figure 16. As the load current increases, the arcing voltage decreases and the conduction voltage of Q increases. When the arcing voltage decreases to less than the conduction voltage of Q, this circuit may not prevent all arcing.

We can ensure that will not happen by adding one component to the circuit of Figure 16. Figure 21 shows the circuit with an added photovoltaic pile, PV.

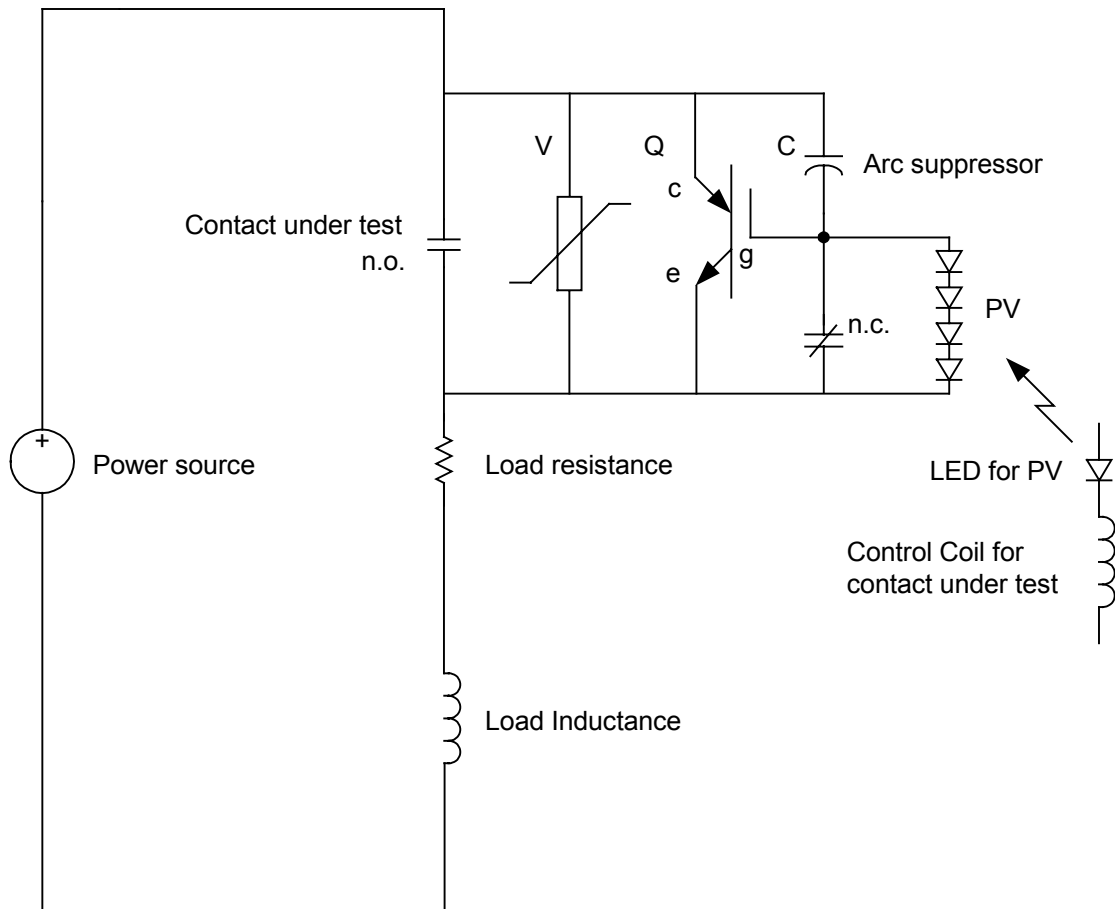

Figure 21: Hybrid Contact Enhanced by a Photovoltaic Pile

The LED that illuminates the photovoltaic pile is placed in series with the control coil of the contact. The photovoltaic pile is turned on when the control coil of the contact is energized. When the control coil is energized, the normally closed contact releases the gate of the transistor, and the photovoltaic pile begins to charge the gate and capacitor C. The photovoltaic pile can produce about 5 volts at about 10 microamps. Charging the gate of Q and C to 5 volts requires about 20 nC, which is delivered by a 10 microamp source in 2 milliseconds.

When the control coil is deenergized, the normally open contacts open, and load current flows through C to the gate of Q as before. However the gate is already at 5 volts, and C is charged to negative 5 volts. To charge the gate from 5 volts to 6 volts only requires adding about 2 nC through C. This decreases the charge on C from negative 5 V to about negative 4 V. Added to

the 6 volts on the gate of Q, this gives a total contact voltage of only 2 volts, compared to almost 12 volts in Figure 20.

Figure 22 zooms in on the instant the normally open contacts in Figure 21 begin to part. Notice that the contact voltage is clamped to about 2 V while the contacts are parting and Q is conducting. Figure 22 depicts a 20 amp interruption. We have used this circuit arrangement to interrupt inductive loads in excess of 100 amps with the same protective relay contact used throughout this paper.

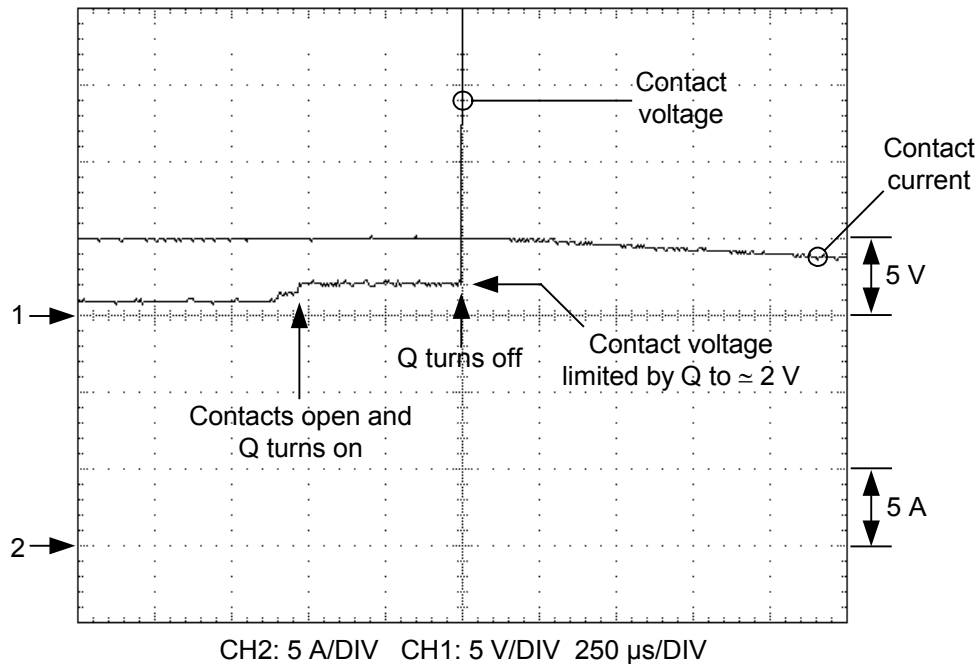

Figure 22: Contact Voltage and Current as the Contacts Part During a 20 Amp Inductive Interrupt

CONCLUSIONS

1. Reed relays can be damaged by seemingly tiny capacitive loads. To ensure that surge capacitors, or even stray capacitance of wiring, do not damage reed relays, insert resistance in series with and near the contact to limit switching current spikes.
2. The interruption process for small contacts, such as those used in modern protective relays, is dominated by glow discharge. The transition from arc to glow discharge is not very repeatable, predictable, or stable.
3. Attempts to increase the interrupting capacity of small contacts by including external components such as flyback diodes, MOVs, or snubbing capacitors may result in a decrease in contact damage at some given interrupted current. However, these added components may not actually extend the switching capacity of those contacts.
4. To be certain that an inductive load is interrupted by a metallic contact not rated to switch such a load, prevent an electrical arc from forming by shunting current around the parting contacts.

REFERENCES

- [1] Jeff Roberts and Tony Lee, "Measuring and Improving DC Control Circuits," Proceedings of the 25th Annual Western Protective Relay Conference, Spokane, WA., October 13 - 15, 1998.
- [2] James D. Cobine, *Gaseous Conductors: Theory and Engineering Applications*, Dover Publications, Inc. New York, 1958.
- [3] IEEE Standard 100-1992, *The New IEEE Standard Dictionary of Electrical and Electronics Terms*, Fifth Edition, Institute of Electrical and Electronics Engineers, Inc., Definition of Negative-Resistance Device, p. 840.

BIOGRAPHIES

Dr. Schweitzer was born in Evanston, Illinois, USA, in 1947. He received his Bachelor's degree and his Master's in electrical engineering from Purdue University. He received his Ph.D. degree from Washington State University, upon completion of his dissertation on digital protective relaying.

Dr. Schweitzer continued his research in digital protective relaying while serving on the electrical engineering faculties of Ohio University and Washington State University. The research covered both theoretical and practical aspects, and demonstrated the feasibility and practicality of digital techniques for protecting electric power apparatus and systems.

In 1982, Dr. Schweitzer founded Schweitzer Engineering Laboratories, in Pullman, Washington, to develop and manufacture digital protective relays and related products and services. Today, SEL is an employee-owned company, which serves the electric power industry worldwide, and is certified to the international quality standard ISO-9001. SEL equipment is in service at voltages from 5 kV through 765 kV, to protect feeders, motors, transformers, capacitor banks, transmission lines, and other power apparatus.

Dr. Schweitzer is recognized as a pioneer in digital protection, and holds the grade of Fellow of the Institute of Electrical and Electronic Engineers (IEEE), a title bestowed on less than one percent of IEEE members.

He has written dozens of technical papers in the areas of distance relay design, filtering for protective relays, protective relay reliability and testing, fault locating on overhead lines, induction motor protection, directional element design, dynamics of overcurrent elements, and the sensitivity of protective relays.

Dr. Schweitzer holds more than twenty patents pertaining to electric power system protection, metering, monitoring, and control.

Tony J. Lee received his B.S. degree in electrical engineering from Washington State University in 1987. Mr. Lee then worked for Texas Instruments in Dallas, Texas from 1987 through 1991, when he joined Schweitzer Engineering Laboratories, Inc. as a hardware design engineer. He presently holds the position of Transmission Engineering Manager at SEL. Mr. Lee holds two U.S. patents and several foreign patents regarding arc suppression and has several patents in process.