

Simplifying and Improving Protection of Temporary and Unusual Bus Configurations With Microprocessor-Based Relays

Casper Labuschagne, Normann Fischer, and Bogdan Kasztenny
Schweitzer Engineering Laboratories, Inc.

Presented at the
67th Annual Georgia Tech Protective Relaying Conference
Atlanta, Georgia
May 8–10, 2013

Originally presented at the
39th Annual Western Protective Relay Conference, October 2012

Simplifying and Improving Protection of Temporary and Unusual Bus Configurations With Microprocessor-Based Relays

Casper Labuschagne, Normann Fischer, and Bogdan Kasztenny, *Schweitzer Engineering Laboratories, Inc.*

Abstract—Breaker substitution, stub bus, and station bypass are temporary substation configurations used to facilitate the maintenance of primary equipment while keeping assets in service and supplying loads. These configurations provide considerable operational advantages but create challenges for protection systems.

Traditional solutions to temporary bus configurations required for electromechanical relays utilize test and bypass switches to ensure the affected relays are provided with the appropriate currents and voltages and the trip signals are routed to the appropriate breakers. In some cases, spare relays, settings changes, and the rerouting of pilot signals and communications have been required. All these manual operations increase the danger of misoperation when making changes, during temporary configurations, or when restoring to the normal configuration. As a result, temporary bus configurations have been carefully considered and often avoided, resulting in underutilization of the network assets.

This paper shows how modern microprocessor-based relays can simplify applications under temporary bus configurations, eliminate the need for any manual reconfiguration, and improve the performance of protection. These benefits stem from the ability to connect multiple current and voltage inputs, the ability to trip multiple breakers, communication between relays, and programmable logic, allowing automatic detection and dynamic response to temporary bus configurations.

I. INTRODUCTION

Breaker substitution, also known as breaker transfer, is the temporary usage of a bus coupler in a multiple-bus configuration to substitute for one of the network element circuit breakers, typically for the maintenance of the circuit breaker. The substituted breaker is isolated via disconnect switches and bypassed by the bypass switch to connect the network element to the transfer bus, while the transfer bus is energized via the bus coupler. As a result, during breaker substitution, both the bus protection scheme and the network element protection scheme must adapt accordingly.

Stub bus refers to an area of a bus or line that becomes isolated from the original zone of protection, typically by an opened disconnect switch. A typical stub bus scenario occurs in a ring-bus or breaker-and-a-half configuration when a transmission line is isolated via an opened disconnect switch but both line breakers are closed to maintain the integrity of the bus. At the same time, the line may be energized, feeding tapped loads or transferring power between the other two terminals of a three-terminal line. This case also requires both the bus protection scheme and the line protection scheme to adapt accordingly.

Station bypass refers to a situation when two lines of the same voltage level that normally terminate on a bus are isolated from the bus but tied together temporarily via a disconnect switch. Such a configuration changes two lines that are normally protected as individual zones by two protection schemes into a single line protected from both remote terminals, while the local station is effectively bypassed. Depending on the location of the current transformers (CTs), the bus relay may need to adapt to this configuration. More importantly, the two line protection schemes need to be reconfigured to effectively form a single scheme.

During unusual and temporary bus configurations, the breaker failure initiate or trip signals must be rerouted accordingly as well. This is a consequence of tripping circuit breakers that are different than normal upon detecting an in-zone fault. This paper reviews protection challenges and typical solutions related to temporary bus configurations.

II. BREAKER SUBSTITUTION

A. Bus Switching Sequences

Consider the double-bus, single-breaker configuration in Fig. 1. Normally, network elements (NEs), such as feeders, transformers, and so on, are connected to either Bus 1 or Bus 2 via disconnect switches, while the bus coupler (BC) is either opened or closed, depending on the preferences related to fault current levels and the selectivity of bus protection. A given network element can be transferred from one bus to another by disconnect switches. Furthermore, one of the two buses can be used as a transfer bus to facilitate breaker substitution. In this switching scenario, the bus coupler is closed first. Then all network elements except for the network element to be transferred are switched to one of the two buses (assume this is Bus 2), while the transferred network element (assume this is NE1) is switched to the transfer bus (Bus 1). Subsequently, the corresponding bypass switch (BP1) is closed. Next, the transferred breaker (CB1) is opened and then isolated by its disconnect switches. At this point, the transfer is complete and the transferred breaker is available for maintenance.

The bus coupler therefore takes over the role of the network element breaker, and the zone of protection now includes the transfer bus and extends to the bus coupler CT opposite to the transfer bus (CTB1 in this example).

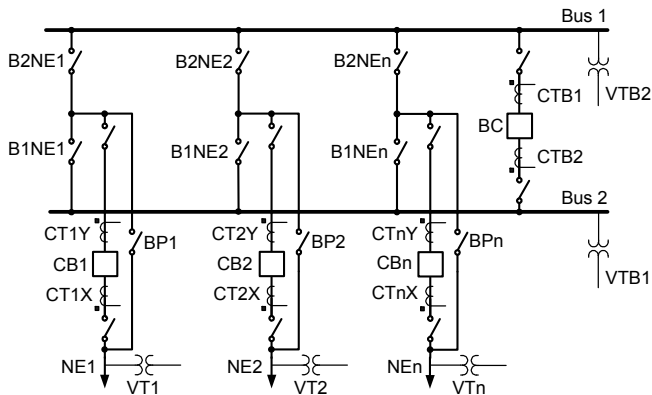

Fig. 1. Double-bus, single-breaker busbar configuration.

B. Bus Protection Challenges and Solutions

To protect the two buses shown in Fig. 1 selectively, the bus protection scheme is required to support at least two bus zones (i.e., two independent differential protection elements). The bus protection scheme uses current from the equipment-side CTs (CT1X...CTnX) and current from the bus coupler CTs (CTB1 and CTB2). The auxiliary contacts of the disconnect switches are used to determine which currents to include in which bus zone.

In general, a bus zone is formed by the bus coupler CT opposite to the protected bus and the equipment-side CTs of the equipment connected to that bus. With none of the disconnect switches closed, the Bus 1 protection zone is bounded by the bus coupler CT opposite to Bus 1 (CTB1), and the Bus 2 protection zone is bounded by CTB2, as shown in Fig. 2. This is known as an overlap bus coupler configuration. When a network equipment disconnect switch is closed onto Bus 1 or Bus 2, then that piece of network equipment is included in that protection zone and its CT currents are included in the bus differential element.

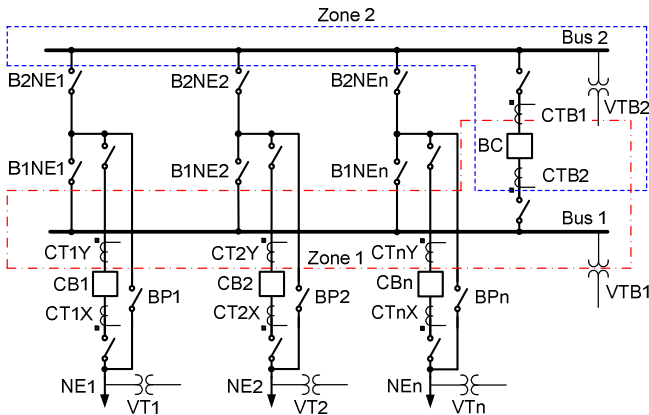

Fig. 2. Double-bus, single-breaker busbar configuration showing the individual bus protection zones.

When a bus fault occurs, the bus zone protection element in the zone in which the fault occurred sends a trip signal to all the network element breakers connected to the faulted bus.

Depending on the status of the bus coupler (i.e., open or closed), a trip signal is also routed to the bus coupler.

For a breaker failure, the bus protection scheme trips the entire bus to which the failed breaker is connected at the time and the bus coupler, in a similar way as for a bus fault.

The first challenge for bus protection is when a network element is transferred from one bus to the other. For example, assume that NE1 is to be transferred from Bus 1 to Bus 2. Initially, the B1NE1 disconnect switch is closed and the B2NE1 disconnect switch is open. To begin the transfer process, B2NE1 is closed, both B1NE1 and B2NE1 are closed, and then B1NE1 is opened. When both B1NE1 and B2NE1 are closed, the two buses are paralleled. While the bus protection scheme measures the total current in the transferred NE1 (via CT1X), it does not know how this current splits between the two buses. Therefore, the two zones of bus protection cannot be protected individually (selectively). Instead, the entire bus is protected by a single bus differential element using all the CTs that bound the two buses (CT1X...CTnX) but excluding the CTs internal to the bus (CTB1 and CTB2).

The bus protection system monitors the position of the disconnect switches and assigns currents to the corresponding bus-zone relay elements. However, there may be a time lag between the change in the disconnect switch status and the current flow in the power system. This time lag can result in a temporary unbalance of the differential elements and an unexpected bus protection operation. To guard against this, an undervoltage supervision element is applied to the bus zone. Therefore, before a bus differential scheme issues a trip signal to the breaker connected to the bus zone, the following two conditions have to be met:

- The differential element must indicate an internal bus fault.
- The phase undervoltage element must indicate an undervoltage condition.

This two-out-of-two trip requirement prevents the protection scheme from operating during a transfer procedure.

Previously, it was mentioned that the bus coupler CTs are excluded when the two buses are in parallel. If the bus coupler CTs are not excluded, the sensitivity of the bus protection scheme is decreased. The reason for this is that the differential element will overrestrain, or even block, due to a current circulating via the bus coupler during a bus fault. Should the fault be a high-resistance fault, the dependability of the relay may be compromised.

Another solution to prevent an undesired bus-zone operation during a transfer operation is to use a check zone, a supervisory differential zone made up of the currents of all the network elements connected to all the buses but excluding the bus coupler element. Generally, this zone is static and does not use the information of the disconnect switches to assign network elements to a zone of protection. For this example,

the check zone is composed of all the equipment-side CTs, namely CT1X...CTnX, as shown in Fig. 3. In this case, before the bus protection scheme can issue a trip, both the faulted bus-zone protection element and the check zone must indicate the presence of an internal bus fault. Again, a two-out-of-two condition must be met before a bus trip is issued.

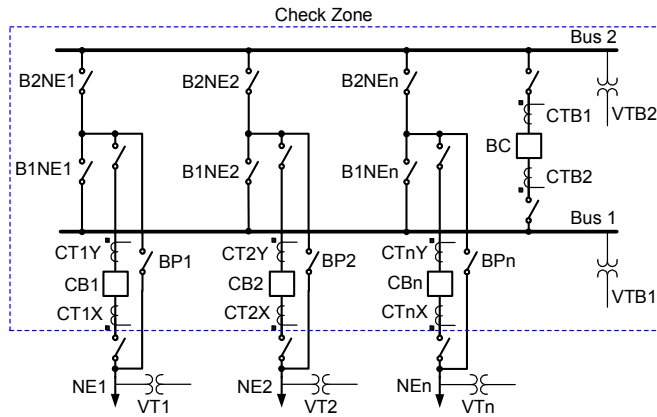

Fig. 3. Check zone for a double-bus, single-breaker busbar arrangement.

What is interesting about the configuration of the check zone is that it is identical to the differential zone for the case when the two buses are paralleled.

The second challenge for bus protection is when the bypass switch is closed as a part of the breaker substitution sequence while the breaker being substituted is still carrying current. Assume that NE1 is connected to Bus 1, all the other network elements are supplied from Bus 2, and the bus coupler is closed. When BP1 is closed, CT1X does not measure the total current flowing into Bus 1 via B1NE1 anymore, as shown in Fig. 4. It measures an unknown portion of this current splitting between the two parallel branches (CB1 and BP1). At this time, Bus 1 cannot be protected with a differential principle because it lacks current measurement in the B1NE1 path. Upon detecting the closing of a bypass switch, the bus protection system inhibits the corresponding bus protection zone. BP1 inhibits Bus Zone 1 in this case.

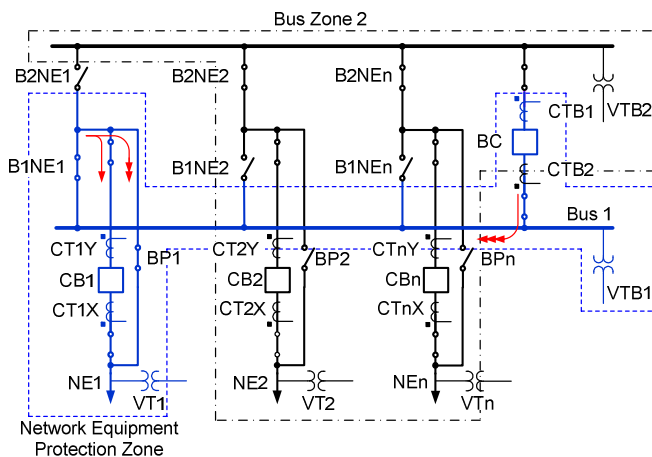

Fig. 4. Distribution of the current between the line CT (CT1X) and the bypass switch and desired protection zones when the bypass disconnect switch is closed.

Again, a time lag can occur between detecting the status of BP1 and the current redistribution in CT1X, and this can lead to misoperation. In this case, a check zone is not effective because it uses the same current CT as the bus zone, namely CT1X. However, undervoltage trip supervision (VTB1) will work to secure the bus protection scheme in this instance.

After the breaker substitution switching procedure, Bus 2 is protected with differential protection and Bus 1 is protected as a part of the NE1 protection zone, which is explained in the next subsection.

If voltage supervision is not available and a check zone option is the only available option, the bus coupler CT (CTB1) needs to substitute the network equipment CT (CT1X) in order to balance the check zone. Although this dynamic adjustment of the check zone makes the check zone dependent on the disconnect auxiliary contacts, it does so only during bypass operations.

C. Network Element Protection Challenges and Solutions

Normally, the protection of network equipment uses bus-side CTs (CTnY) and equipment-side voltage transformers (VTs), and the zone of protection overlaps with that of the bus zone at the circuit breaker (CBn). Breaker substitution affects the protection of the network element. With the bypass switch (BPn) closed, the bus-side CTs no longer measure the total current of the network equipment. As a result, the network equipment protection must be switched from the bus-side CTs to the bus coupler CTs (CTB1 or CTB2). By doing this, the network protection not only includes the network equipment but also the bus to which the network equipment is connected during the breaker substitution temporary bus configuration. Depending on the location of the VT, the network protection relay may need to switch from the equipment-side VT (VTn) to the bus VT (VTB1 or VTB2).

Switching the protection current measurement and trip paths from the regular breaker to the bus coupler breaker can be achieved in several ways. Assume the transferred NE is a line.

One solution is to use the same line relay but to transfer the required signal from the bus coupler to the line relay. This method makes use of a set of external auxiliary relays that switch the bus coupler CT, breaker I/O contacts, breaker failure initiate signal, and, if required, the bus VT to the network equipment relay. Fig. 5 is a simple sketch of this solution for a breaker substitution.

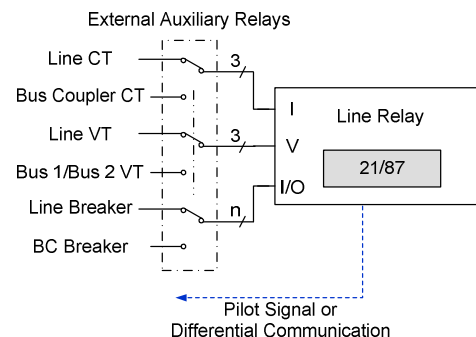

Fig. 5. Breaker substitution scheme where auxiliary relays are used to route the coupler currents and voltages to the network equipment relay.

When the piece of network equipment is placed in the transfer mode, the auxiliary relays are energized and the network equipment relay is supplied by the bus coupler CTs, VTs, and the I/O from the bus coupler breaker. The interlocking in this instance is such that only one piece of network equipment can be placed in transfer mode at a time. This solution requires that the CT auxiliary relays be capable of switching and carrying the full load current of the CTs, as well as fault current.

Advantages of this scheme are that relay settings do not need to be altered during a transfer and the communications signals or channels do not require rerouting. A further benefit of this scheme is that it does not really matter what type of network equipment (feeder, transformer, and so on) is being placed on transfer.

A disadvantage of this scheme is that it is expensive (cost of the auxiliary relays and scheme engineering). This scheme has a moderate level of complexity, and because the transfer process is done manually, it is prone to human errors. Also, the existence of switching devices in the ac and dc wiring lowers the overall reliability of the scheme and creates safety concerns, especially in relation to switching the CT secondary currents.

A second solution for breaker substitution is to use a spare relay, known as a transfer relay, at the bus coupler. This relay is wired to the bus coupler CTs and VTs (if required) and the I/O of the bus coupler breaker. This relay is configured prior to substitution to protect different pieces of network equipment connected to the buses.

When a network element is placed on transfer, then the transfer permission switch from the breaker being substituted initiates an alternate settings group in the transfer relay. This solution requires the communications signals, whether those of a communications-aided tripping scheme or a differential scheme, to be rerouted. A realization of this scheme is sketched in Fig. 6.

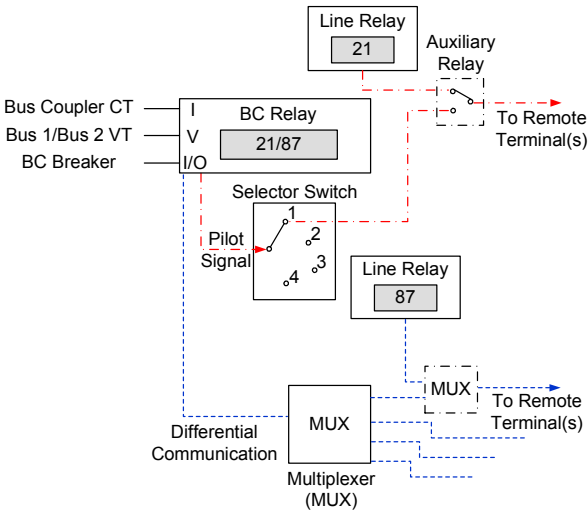

Fig. 6. Breaker substitution scheme in which a transfer relay is used at the bus coupler. This scheme requires the communications channels to be switched.

This scheme has several drawbacks in that the number of breakers that can be substituted is limited by the number of

settings groups available in the transfer relay. Furthermore, this scheme requires a transfer relay for each different piece of network equipment connected to the bus. For example, if a shunt capacitor bank breaker were to be substituted, the transfer relay would need to be capable of providing shunt capacitor bank protection. Even though this approach may work well for line and shunt capacitor banks, it cannot be used when the substituted breaker is a transformer high- or low-side breaker. Owing to these shortcomings, this scheme is not as popular as the previous scheme.

Generally, utilities standardize on one bus to be used as the transfer bus to decrease the errors associated with breaker substitution. This leads to a third and better solution than the two methods described previously in that each new network element has a multi-input microprocessor-based relay with the programmability to internally switch its protection functions from one set of inputs and outputs to another set.

For our example two-bus system, assume that Bus 1 is selected as the transfer bus. This means that both the network equipment bus-side CTs and the bus coupler CTs (in this example, CTB1) are permanently connected to the relay. In addition, both the network equipment breaker I/O and the bus coupler I/O are connected to the protective relay. A sketch of this solution is shown in Fig. 7.

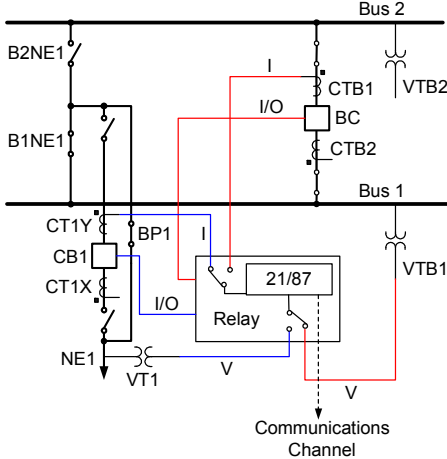

Fig. 7. Breaker substitution scheme using a modern relay with multiple VT and CT input terminals to facilitate breaker substitution. The relay selects the appropriate analog and digital quantities internally.

Similar to the first solution, communications signals are not required to switch and the relay does not need to change any settings because it continues to protect the same network element. The relay monitors the position of the bypass switch (BP1) and selects the correct voltages, current, and breaker I/O contacts to use.

Again, a time lag can occur between the current redistribution and the status of the bypass switch. Undervoltage trip supervision is sufficient to prevent misoperation. If required, the relay can measure both VT1 and VTB1 and switch to the bus voltage if VT1 does not represent the network element voltage during the substitution.

Of all the solutions presented here, the third is the preferred solution because of its simplicity and avoidance of any external auxiliary relays and manual reconfiguration

requirements. The third solution does not require any manual reconfiguration, thereby eliminating any possible errors during a breaker substitution.

D. Breaker Failure Considerations

In a dynamic bus configuration, breaker failure trip signals must be routed based on the present bus connection in order to isolate the fault despite the failed breaker, while, at the same time, not tripping breakers not contributing directly to the fault. In complex bus arrangements, the bus protection scheme is responsible for routing any bus or breaker failure trip signals because it has access to the status of all disconnect switches and breakers. When breakers are correctly assigned to bus protection zones for all the possible dynamic conditions, breaker failure tripping is straightforward—in order to isolate a fault, the bus system must trip the entire bus to which the failed breaker is presently connected (i.e., trip all breakers presently connected to the same bus).

The same rule applies to the breaker substitution situation as well. Using the dual-bus system shown in Fig. 7 as an example, if the bus coupler breaker fails for an NE1 fault while the bus coupler is substituting the network equipment breaker, the bus protection scheme needs to clear Bus 2. In this situation, both buses are cleared and all the network elements are disconnected, unlike during normal operation when a breaker failure clears only one of the two buses. This is a reason to limit the duration of the breaker substitution temporary bus configuration.

In addition to clearing Bus 2, the bus protection scheme must initiate a direct transfer trip (DTT) to all breakers of the NE1 zone (the breaker(s) of the element being substituted). If NE1 is a power line, this can be done by using the NE1 relay to send a DTT to all remote terminals of the NE1 line.

III. STUB BUS CONFIGURATION

Stub bus configuration typically applies to double-breaker connections of network elements. Fig. 8 shows a network element connected via two breakers (ring-bus, breaker-and-a-half, or double-bus, double-breaker bus configurations). Stub bus refers to a condition when the network element disconnect switch is opened but the two breakers remain closed in order to maintain the integrity of the bus. At the same time, the network element may remain energized or even serve loads (three-winding transformer, three-terminal line, or tapped line). The opened disconnect switch effectively breaks the original zone of network element protection into two zones. This can cause both selectivity and dependability problems, such as the following:

- The area between the two breakers and the opened disconnect switch (stub bus) needs protection, and the network element protection may lose the ability to protect this area properly.
- The network element should not be tripped for faults within the stub bus.
- The network element must be protected properly, despite the opened disconnect switch.

- Tripping the network element should not include the breakers of the stub bus.
- Breaker failure trips need to be routed to the appropriate breakers.

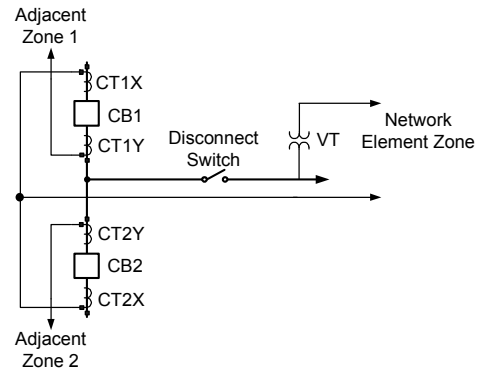

Fig. 8. Stub bus configuration.

A. Security of Detecting the Stub Bus Condition

The stub bus condition is detected based on the position of the disconnect switch. Because protection logic changes considerably in response to the stub bus condition, the stub bus signal must be very reliable. Typically, a spurious assertion of the stub bus logic will cause a false trip. At the same time, the auxiliary contacts of the disconnect switches are known for their relatively poor performance. As a result, it is customary to use both the 89a and 89b contacts when sensing the position and apply discrepancy logic to send an alarm with the intent to rectify any problems [1] [2].

B. Impact on Bus Protection

The bus protection system can be used to provide stub bus protection. Assume that Adjacent Zone 1 in Fig. 8 is the bus protection zone. Normally, the bus protection scheme would use CT1Y to terminate its zone of protection at the CB1 breaker. Under the stub bus condition, the bus scheme can dynamically switch from CT1Y to CT2X. This way, the bus zone includes the stub bus. Of course, this operation is convenient when using a low-impedance microprocessor-based bus relay, with both CT1Y and CT2X wired to the relay and switched internally via programmable logic in response to the position of the disconnect switch. However, this solution is not optimal from the point of view of selectivity—faults within the stub bus will result in tripping the entire bus. One solution to this weakness is to initiate sequential tripping from the bus zone. First, CB1 and CB2 are tripped. If the bus differential element resets, the fault was in the stub bus area and therefore the other bus breakers are not tripped. If the bus differential element remains picked up, the fault must be truly on the bus and the entire bus is tripped. A slower bus fault clearing time is a disadvantage of the sequential tripping solution. Another solution is to enable a two-current differential zone within the bus protection scheme, utilizing just the CT1X and CT2X current measurements, and enable this zone under stub bus conditions. This, however, requires the bus relay to support extra zones of protection.

C. Impact on Network Element Protection

The network element relay can be used to protect the stub bus. Typically, a simple instantaneous overcurrent element responding to the sum of the CT1X and CT2X currents or a differential element is used. This protection is enabled only under the stub bus condition. The differential element solution is more secure under CT saturation for close-in faults compared with a simple overcurrent element. When tripping from the stub bus protection, the network element relay trips only CB1 and CB2 and does not trip the other breakers of the network element.

In addition, the network element protection must continue to protect the network element. In this respect, the issues and solutions differ depending on the type of protection.

1) Transformer Protection (87T)

If the network element is a transformer with differential protection (87T), the stub bus is within the 87T zone of protection and therefore there are no concerns with dependability. However, if the transformer is to remain energized and to achieve selective operation, the CT1X and CT2X currents can be dynamically removed as inputs of the transformer differential element 87T upon a stub bus configuration. Some modern transformer relays allow such dynamic assignment of currents. When tripping from the 87T element, the relay should not open the CB1 and CB2 breakers. To complete this solution, the stub bus can be protected using a bus relay or an overcurrent element within the transformer relay responding to the sum of the CT1X and CT2X currents.

2) Line Distance Protection

Line distance protection does not work properly under stub bus conditions with the VT on the line side of the disconnect switch because the voltage and current measurements are taken in portions of the network that are separated by the opened line disconnect switch. When the VT is connected on the bus side of the line disconnect switch, distance protection protects the stub bus. When tripping from Distance Zone 1 under stub bus conditions in applications with bus-side VTs, ensure that no DTT signal is sent to the remote line breakers.

3) Directional Comparison Permissive Schemes

In order to properly protect the line under stub bus conditions, apply echo keying or permanently assert the permissive signal when the line disconnect switch is opened. This permissive signal allows the forward-looking overreaching elements at the remote terminal to trip instantaneously for all faults on the line.

4) Directional Comparison Blocking Schemes

Blocking schemes allow instantaneous tripping if no blocking signal is asserted. Therefore, blocking schemes work correctly under stub bus conditions without any modification.

5) Line Current Differential (87L) Protection

Because stub bus configurations are more often applied to lines rather than transformers, 87L relays typically provide for a built-in stub bus mode of operation. Upon a stub bus configuration, the following occurs:

- The local relay sends zeros as the value of the local current to the remote 87L relay (or relays). This way, the line differential zone of protection provided by the remote 87L relay (or relays) terminates at the opened disconnect switch.
- The local relay substitutes the received currents with zeros. This way, the local 87L zone becomes a stub bus differential zone and terminates at the opened disconnect switch (a differential element using just CT1X and CT2X).
- Received DTT signals are ignored at the terminal with the stub bus (they originate for line faults, and line faults are already isolated from the local terminal by the opened disconnect switch).
- When tripping from 87L under a stub bus condition, DTT signals are not sent to the remote 87L relays (these relays do not have knowledge of a local stub bus condition and cannot decide by themselves to execute or suppress any received DTT signals).
- Some other more sophisticated aspects of 87L operation can be designed into the stub bus configuration (examples are external fault detection or charging current compensation [3]).

6) Loss-of-Potential (LOP) Logic

In applications with line-side VTs, LOP logic that is based on the change of voltage and current can malfunction by sensing a change in the voltage due to faults while not seeing any change in the currents because of the opened disconnect switch. Typically, there are other paths—even if weak—that connect the VT point with the CT points (parallel lines), making this scenario less likely. However, in general, we can see spurious LOP indications under stub bus conditions.

D. Impact on Breaker Failure Protection

Under stub bus conditions, the two local breakers (CB1 and CB2) are isolated from the network element. Therefore, upon CB1 or CB2 failure, DTT signals should not be sent to the other breakers of the network element.

IV. STATION BYPASS

Station bypass is an operation that mainly occurs at subtransmission levels where the station bus configuration is relatively simple and no bus coupler or transfer bus is available to allow the substitution of a breaker [4]. These substations may sometimes be referred to as looped substations, meaning a feeder simply loops into or through the substation.

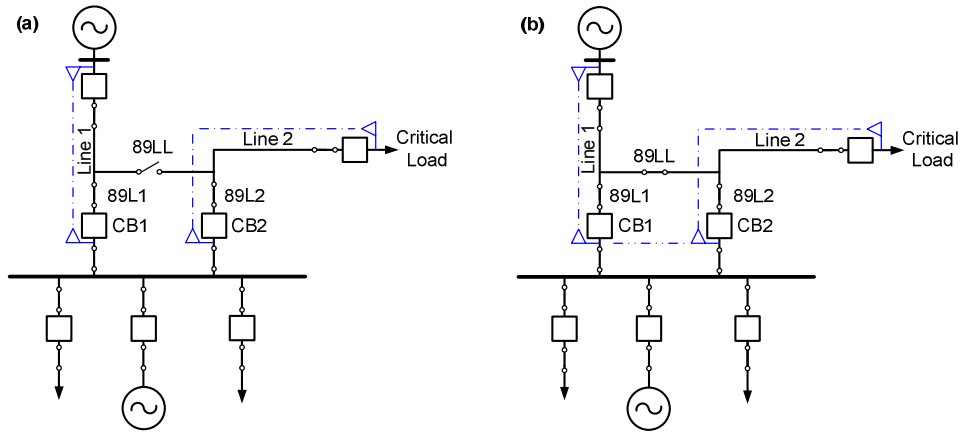

Fig. 9. Normal operating condition with bypass switch 89LL open and two independent feeders (a). Bypass switch closed and circuit transformed from two two-terminal lines to one four-terminal line (b).

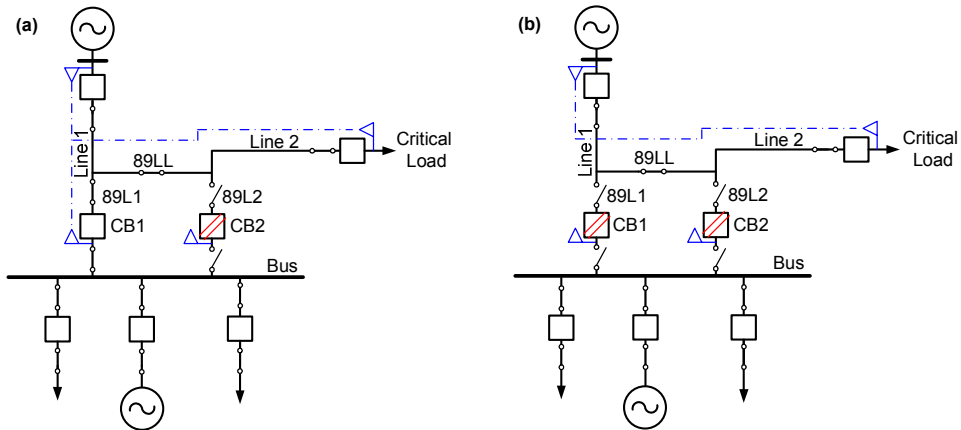

Fig. 10. Breaker requiring maintenance and associated line switch open and the line transformed from a four-terminal line to a three-terminal line (a). Remaining local breaker and line switch opened, and the line transformed from a three-terminal to a two-terminal line and the station bypassed (b).

A. Switching Sequence

To explain the need for station bypass and the switching sequences involved, consider the bus arrangement in Fig. 9a. If breaker CB2 needs to be taken out of service for routine maintenance and the supply to a critical load must be maintained, a bridge or link has to be created between the source and load. To accomplish this link between Lines 1 and 2 in Fig. 9a, the 89LL disconnect switch is used.

To place a feeder on station bypass, the following switching sequence is executed:

- Close the bypass switch (89LL in this example), as shown in Fig. 9b.
- Open circuit breaker CB2 and then line link 89L2, as shown in Fig. 10a.
- Open circuit breaker CB1 and then line link 89L1, as shown in Fig. 10b (this step is optional and is dependent on the utility operating philosophy or system condition at the time).

To return the feeder to its normal operating condition, the operating procedure is executed in the reverse order.

B. Bus Protection Challenges and Solutions

The bus configuration shown in Fig. 9a can be equally well protected by a high- or low-impedance bus differential relay.

A high-impedance scheme would generally be a more economical choice but poses a challenge in how to handle the CTs associated with the out-of-service breaker(s) (see Fig. 10). This concern is addressed by routing the CTs through the auxiliary contacts of the line disconnect switches 89L1 and 89L2, as shown in Fig. 11. These auxiliary contacts need to be early make, late break contacts [2].

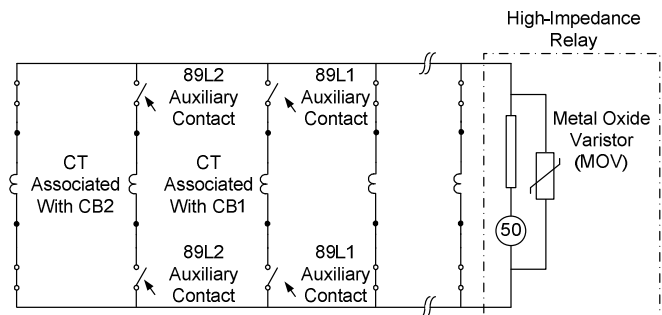

Fig. 11. Routing CT leads through auxiliary contacts of line disconnect switches enables CT switching in a high-impedance bus protection scheme.

Because the operating procedures and interlocking philosophy are such that line breakers are opened before the line disconnect switches are, there is no risk of ever open-circuiting a CT under load conditions.

If a low-impedance bus differential relay is used to protect the bus, no physical CT switching is required and the CTs associated with the out-of-service breaker(s) are removed from the differential protection zone dynamically by the relay programmable logic using the status of the line disconnect auxiliary contacts [1] [2]. If the line disconnect switch is closed, the CT is considered in zone, and if the line disconnect is open, the CT is considered out of zone. The low-impedance bus differential approach avoids CT switching. Check zone and undervoltage supervision are not required because, at the time of switching, the currents are zero (the breakers are opened).

C. Line Protection Challenges and Solutions

When the bypass link (89LL) is closed, the two independent lines (Lines 1 and 2) are transformed from two two-terminal lines to one four-terminal line (see Fig. 9b).

When one of the local breakers and its associated line disconnect switch are opened, the line is transformed from a four-terminal line to a three-terminal line (see Fig. 10a). Depending on the operating philosophy or system conditions, the other remaining local breaker and associated line disconnect switch may be opened, transforming the line from a three-terminal line to a two-terminal line. Accordingly, the line protection has to be adjusted to effectively protect the reconfigured line. In this paper, we consider both distance and differential protection of the line. Even though these protection methods may seem to have common attributes, their differences validate dealing with the two protection methods separately.

1) Distance Protection

To afford 100 percent protection for both lines during the switching sequence, the settings of the distance relays at all locations need to be adjusted to reflect those of the power system being protected.

During the first step of the station bypass when the line is transformed into a physical four-terminal line, the protection of the lines (Lines 1 and 2) requires the overreaching zone reaches of the remote relays to be set so that each remote relay can see past the other remote terminals, considering infeed from the terminal(s) at the bypass station, as shown in Fig. 12a. The overreaching zones of each of the local relays (relays at the bypass station) have to be such that each relay can see past the farthest remote relay terminal. At the same time, the reverse reach of the local relays has to be checked to ensure coordination with the overreaching zones of the remote relays (α in Fig. 12a should be set so that the reverse-reaching element can see at least 10 percent further back than the forward-reaching zone of the remote terminal). Note that none of the instantaneous or underreaching zone reaches at any of the relay locations requires a settings change from its normal settings value.

For the second step of the bypass (as shown in Fig. 12b) when one of the local breakers is taken out of service (out of service in this paper means the breaker is open and the associated disconnect is open), no settings at any of the relay locations need to be changed if the settings at the remote relays and at the local relay are such that each overreaching zone can see past the farthest terminal and the reverse zones are set to correctly deal with the extended overreaching zones.

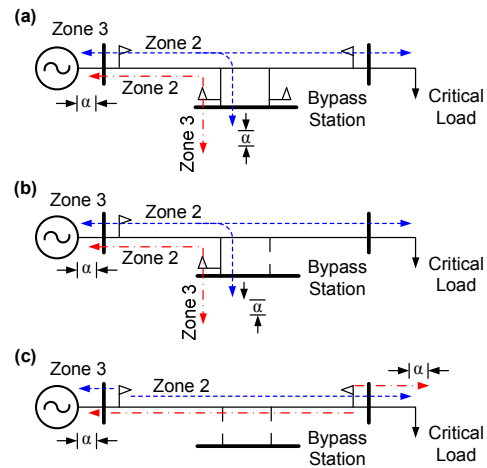

Fig. 12. For the first step of the bypass procedure, the line is a four-terminal line (a). For the second step of the bypass, one local breaker is taken out of service and the line becomes a three-terminal line (b). For the third and final step of the bypass, the second local breaker is taken out of service and the combined line becomes a two-terminal line (c).

For the final step of the bypass, when both local breakers are taken out of service, no settings changes are required at the local relays if they are configured correctly so as to not initiate a trip to an already open breaker. The remote relays require a settings change in their communications-aided scheme logic because they transitioned from a multiterminal system to a two-terminal system. The overreaching zones do not require change, but the underreaching zones can be extended so that they cover a greater percentage of the combined line. Details of how this is accomplished are discussed in the following paragraphs.

In essence, the bypass of the station can be broken up into the following two parts:

- Adapting the settings and control of the relays at the bypass station (local relays).
- Adapting the settings of the remote terminal relays.

At the bypass station, the whole bypass process can be made less complex and more reliable if the relays have access to the current in the adjacent line and are capable of controlling the adjacent line breaker. As mentioned in Section II, modern distance protection relays are capable of supporting multiple current and voltage input terminals.

The Line 1 relay in Fig. 13 measures the current in its own line (I_{LINE_1}) and the current in the adjacent line (I_{LINE_2}). Simultaneously, the Line 1 relay has access to and can control the Line 2 breaker. The Line 2 relay mirrors the logic of the Line 1 relay. The status of the disconnect switches is used to inform the relays of the configuration of the power system.

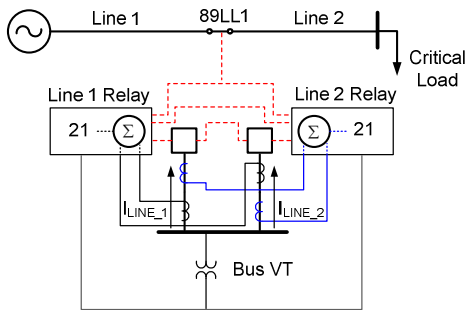

Fig. 13. Suggested setup at the bypass substation to facilitate a more reliable station bypass.

When both line breakers are closed and the bypass link closes, the current used by the distance elements should switch from that of Line 1 (I_{LINE_1}) to the sum of the two line currents ($I_{LINE_1} + I_{LINE_2}$). This is equivalent to placing a virtual CT measuring the current at the tap created between the two lines by closing the 89LL disconnect switch.

At the same time, any trip or reclose decision made by any one of the line relays will operate both of the local breakers, because the two breakers operate in parallel and are in series with the tap created by closing the 89LL disconnect switch.

Since both local relays are set identically, we can say that at this stage, one relay is a backup for the other relay. In this manner, the four-terminal line can be considered as a three-terminal line, as shown in Fig. 14.

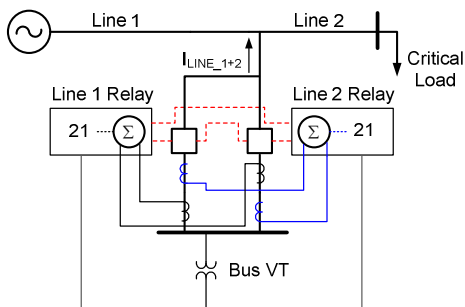

Fig. 14. When viewed from an electrical point of view, the physical four-terminal line can be, in effect, a three-terminal line if the two currents at the bypass station (local) are simply summed together.

In the arrangement shown in Fig. 14, the communications schemes in the two relays can be kept separate in that each relay only communicates to its original remote terminal and not to the adjacent line remote terminals. So in order for a line relay to send a permissive signal to the adjacent line relay remote terminal, a cross trigger arrangement is made between the two local relays whereby an output from one relay asserts an input in the adjacent relay, which, in turn, initiates the communications signal if the 89LL switch is closed. This arrangement has a further advantage in that the relays are not required to transition from a two-terminal communications

scheme to a three-terminal communications scheme and then back to a two-terminal communications scheme. Also, to enable a three-terminal communications scheme would require a communications channel between the two remote terminals.

Depending on whether the bypass station has an alternative source or not, the weak infeed echo logic would need to be enabled in the communications scheme. This scheme can easily handle any further switching of the bypass station, such as the case in which one of the local breakers is taken out of service, by simply disregarding the current from that breaker. At the same time, the logic is adjusted so as not to issue a trip signal to the out-of-service breaker. When both the local breakers are taken out of service (disconnect switches are opened), both local relays still remain in service, with the exception that the local relays do not operate the local breakers. If both the local breakers are out of service, the communications logic is modified so that the local relays simply repeat or pass through the signals they receive from the remote relays, as shown in Fig. 15. Should one of the relays be required to be taken out of service, an external repeater relay can then be used to simply repeat the signals.

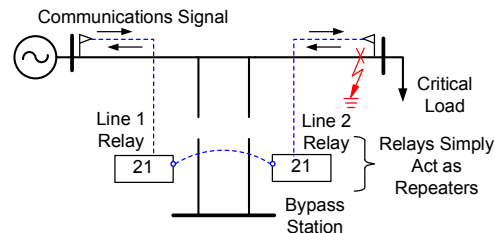

Fig. 15. When both breakers at the bypass station are taken out of service with the line in the bypass mode, the local protective relays can act as repeaters for the communications signal to enable the communications-aided scheme.

A further advantage of the scheme is that it can also deal with the case in which the critical load bus may be connected to an alternative power source.

The other issue that needs to be addressed is informing the remote terminal relays about the changes occurring at the bypass substation. This can be done by using the same communications channel as the protection communications scheme and reserving two extra communications bits. One bit is to inform both remote relays that the bypass link has been closed and to adjust their overreaching zones accordingly. The second bit is used to indicate that both local breakers are out of service and that the instantaneous zone reaches can be extended so that a greater part of the combined line can be protected by these elements.

The advantage of the previous scheme is that for each system configuration, a separate settings group can be preconfigured. This means that for each switching configuration of the power system, the lines are appropriately protected. An extra benefit of the scheme is that it is fully automated by using the appropriate link status to select the corresponding settings group.

2) Differential Protection

Differential elements work on the principle of Kirchhoff's current law. Therefore, for a differential element to effectively

protect a piece of apparatus, it needs to see all the currents that enter or leave the protected zone. For the station bypass case under normal operating conditions (Fig. 16a), there are two separate two-terminal lines protected by a pair of line differential relays providing instantaneous protection for both lines. However, when the bypass link is closed, the two two-terminal line protection zones transition to a single four-terminal line protection zone, as shown in Fig. 16b.

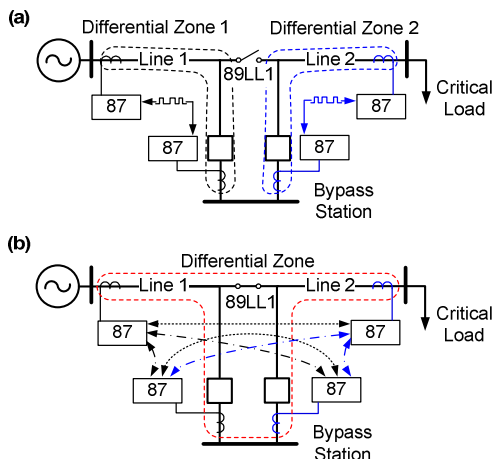

Fig. 16. Normal operation with two two-terminal line differential zones (a). Three-terminal differential zone with the bypass switch (89LL) closed (b).

We could use a brute force method and simply require that each differential relay now have access to all the currents that enter the protection zone, as in Fig. 16b. This requires that communications channels exist between all the stations and that the differential relays be capable of being configured as four-terminal differential relays. One way to ensure connectivity between all four relays is to use Ethernet for 87L protection over a deterministic transport method, such as a synchronous optical network (SONET).

If all of the above requirements are met, then it is definitely possible and feasible to preconfigure a modern line differential relay to adapt to the changing configuration of the power system by making use of the different available settings groups within the relay. Again, the statuses of the local and bypass disconnect switches are used to enable the different settings groups.

Should all communications channels not be available or should the line differential relay not be capable of being configured as a four-terminal differential relay, then there are more elegant methods available to protect the lines during power system reconfiguration. In this paper, we consider the following two different scenarios:

- Communication is available between all substations, and the relays are only capable of being configured as either two- or three-terminal line differential relays.
- The only communications channels available are those that normally exist between the remote substation and the local substation, no direct communication is available between the two remote substations, and the differential relays are only capable of being configured as two- or three-terminal line differential relays.

If we consider the first scenario, in which we have communications channels available between all substations, the relays at each substation would be preconfigured to adapt to the changing power system configuration. As shown in Fig. 17, the protective relays at the source substation and the critical load substation have a communications channel between them, and similarly as with the distance protection scheme, the relays at the bypass substation have access to the current and breaker I/O from the adjacent feeder.

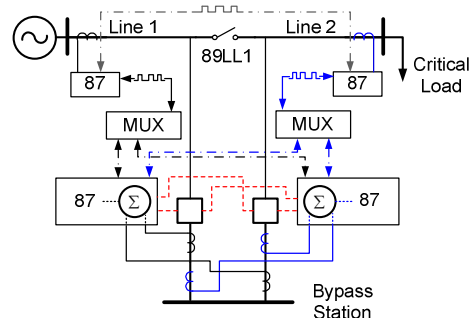

Fig. 17. Setup of the protective relays when there are communications channels between all substations and the differential relays are capable of protecting a three-terminal line.

When the bypass link is closed, all relays in the scheme change from two-terminal mode to three-terminal mode and the zones of protection change from two independent zones to one common zone, as shown in Fig. 16b. At the bypass station, one of the relays becomes the main protective relay and the other relay goes into standby mode, as shown in Fig. 18. In standby mode, the relay is fully functional with the exception that it does not run its 87L element. This is because the remote relays expect a single 87L relay at the bypass station to be a part of the three-terminal 87L scheme. This is different than in the distance scheme where the data packets in the communications signals do not bypass their origin. However, in the differential scheme, the data packets contain the origin of the packet for the purpose of avoiding cross-connections and loopbacks. Even though both local relays could consume the data from the remote terminals and send the total current of the tap created by the closed 89LL switch, only one relay can be a part of the three-terminal 87L scheme.

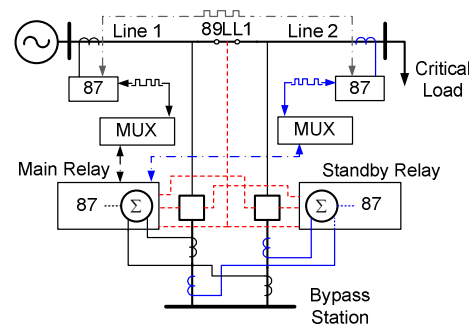

Fig. 18. Configuration of a differential protection scheme when the bypass link is closed and the power system is configured as a four-terminal line. Only one of the bypass station relays is available in the protection scheme, thereby turning this application into a three-terminal line.

The scheme is set up such that if the main relay fails or is taken out of service, it automatically transfers the communication and protection to the standby relay and the standby relay is set identically to the main relay; even its transmit address is the same. This means that if the protection transitions from the main relay to the standby relay, the remote relays will not be able to detect this transition, with the exception that there will be a few missing packets because of the time taken for the local relay to begin transmitting data packets to the remote terminals. In this scheme, all relays are master relays, meaning that each terminal performs its own differential calculation and is responsible for initiating its own trip command.

When one of the local breakers is taken out of service, the scheme does not require any settings changes. When both the local breakers are out of service, the scheme has the option to remain in a three-terminal mode or switch to a two-terminal mode. In either case, the relays at the bypass substation do not issue any trip commands and the relays at the remote substations either use the zero current sent to them from the bypass station (three-terminal mode) or work with just the remote station currents (two-terminal mode).

In the second scenario, shown in Fig. 19, where there is no communication between the two remote substations and the protective relay is capable of protecting a three-terminal line, the setup is similar to the one shown in Fig. 17.

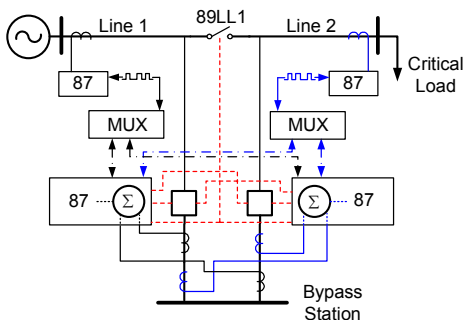

Fig. 19. Setup of the protective relays when communications channels exist only between the remote terminals and the individual relays at the bypass substation.

The difference between this arrangement and that shown in Fig. 17 is that when the power system is reconfigured (i.e., the two lines combined to become a single line with four terminals, a three-terminal single line, or a combined two-terminal line), the only relays that see all the currents in the protection zone are the relays located at the bypass bus, as shown in Fig. 20. Therefore, these are the only relays capable of executing the differential calculation and being the master relays. The remote relays simply feed current data to and execute 87L trip commands from the master relays at the bypass substation during the reconfiguration of the power system and therefore merely act as slave devices. These slave

devices do not have the ability to make their own tripping decisions, and therefore, the trip decision is communicated to them from the master relays via the communications channel.

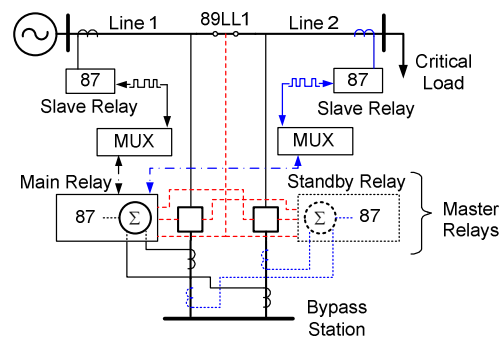

Fig. 20. Configuration of a differential protection scheme when the bypass link is closed and the power system is configured as a four-terminal line and no communication exists between the relays at the remote terminal.

Because the remote relays can only act as slave relays, there are a few drawbacks to this scheme. The first is that the relays at the bypass station cannot be taken out of service, even if the line is in a complete bypass mode (i.e., both local breakers are out of service, as shown in Fig. 21).

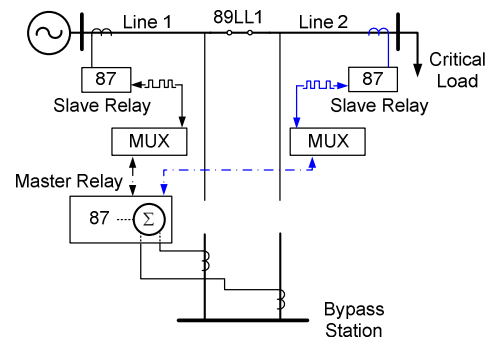

Fig. 21. Final configuration of the power system and the protection system when no communication exists between the remote relay terminals.

The remote breakers are tripped slightly slower because they need to wait for the trip command to be sent back from the master relay. This is typically not an issue, however, because of the voltage level at which station bypass is typically allowed.

The advantage of both these schemes is that multiple settings groups can be preprogrammed using different settings for each possible configuration. In this way, the relays can follow the reconfiguration of the power system and afford maximum protection to the power system at all times. The appropriate settings group can be selected using the status of the disconnect switches at the bypass station. In this fashion, the whole bypass procedure can be automated and the possibility of errors during the bypass procedure can be reduced.

V. CONCLUSION

Temporary bus configurations allow greater utilization of power system assets but create challenges for protection systems.

Traditional solutions to temporary bus configurations required that electromechanical relays use test and bypass switches to ensure the affected relays were provided with the appropriate currents and voltages as well as that the trip signals were routed to the appropriate breakers. In some cases, spare relays, manual settings changes, and the rerouting of pilot signals were required. All these manual operations increased the danger of misoperation when making changes, during temporary configurations, or when restoring to the normal configuration. As a result, temporary bus configurations have been carefully considered and often avoided, resulting in the underutilization of network assets.

This paper describes how modern microprocessor-based relays can simplify applications under temporary bus configurations, eliminate the need for any manual reconfiguration or settings changes, and improve the performance of protection. These benefits stem from the ability to connect multiple current and voltage inputs, the ability to trip multiple breakers, communications between relays, multiple settings groups, and programmable logic that allows an automatic detection and dynamic response to temporary bus configurations.

VI. REFERENCES

- [1] C. Labuschagne, R. Moxley, E. Jessup, and J. Needs, "Low-Impedance Bus Differential – Security and Reliability in Complex Bus Arrangements," proceedings of the 11th International Conference on Developments in Power System Protection, Birmingham, UK, April 2012.
- [2] L. Steenkamp, C. Labuschagne, and E. Stokes-Waller, "Tutorial: Complex Busbar Protection Application," proceedings of the 34th Annual Western Protective Relay Conference, Spokane, WA, October 2007.
- [3] B. Kasztenny, G. Benmouyal, H. J. Altuve, and N. Fischer, "Tutorial on Operating Characteristics of Microprocessor-Based Multiterminal Line Current Differential Relays," proceedings of the 38th Annual Western Protective Relay Conference, Spokane, WA, October 2011.
- [4] D. A. Tziouvaras and W. D. Hawbaker, "Novel Applications of a Digital Relay With Multiple Setting Groups," proceedings of the 17th Annual Western Protective Relay Conference, Spokane, WA, October 1990.

VII. BIOGRAPHIES

Casper Labuschagne earned his Diploma (1981) and Masters Diploma (1991) in Electrical Engineering from Vaal University of Technology, South Africa, and is registered as a Professional Technologist with ECSA, the Engineering Council of South Africa. After gaining 20 years of experience with the South African utility Eskom, where he served as senior advisor in the protection design department, he began work at Schweitzer Engineering Laboratories, Inc. in 1999 as a product engineer. He transferred in 2003 to the research and development group, where he held the position of senior power engineer. In 2009, he was promoted to transmission engineering development manager. His responsibilities include the specification, design, testing, and support of protection and control devices. Casper holds one U.S. patent and has three more patents pending. He has written and co-written several technical papers in the areas of protection and control.

Normann Fischer received a Higher Diploma in Technology, with honors, from Witwatersrand Technikon, Johannesburg in 1988, a BSEE, with honors, from the University of Cape Town in 1993, and an MSEE from the University of Idaho in 2005. He joined Eskom as a protection technician in 1984 and was a senior design engineer in the Eskom protection design department for three years. He then joined IST Energy as a senior design engineer in 1996. In 1999, he joined Schweitzer Engineering Laboratories, Inc. as a power engineer in the research and development division. He was a registered professional engineer in South Africa and a member of the South Africa Institute of Electrical Engineers. He is currently a senior member of IEEE and a member of ASEE.

Bogdan Kasztenny is the R&D director of technology at Schweitzer Engineering Laboratories, Inc. He has over 23 years of expertise in power system protection and control, including ten years of academic career and ten years of industrial experience, developing, promoting, and supporting many protection and control products.

Bogdan is an IEEE Fellow, Senior Fulbright Fellow, Canadian representative of CIGRE Study Committee B5, registered professional engineer in the province of Ontario, and an adjunct professor at the University of Western Ontario. Since 2011, Bogdan has served on the Western Protective Relay Conference Program Committee. Bogdan has authored about 200 technical papers and holds 20 patents.