

Event Analysis Tutorial

Part 1: Problem Statements

David Costello, Schweitzer Engineering Laboratories, Inc.

Abstract—Event reports have been an invaluable feature in microprocessor-based relays since the initial introduction of the technology. The days of unknown root cause for an operation, lengthy outages, or unexplained test results are largely over due to this tool and the ability of engineers and technicians to use it. We must practice to become proficient at analyzing event reports. This session provides real-world event examples, time to evaluate them, and solutions.

I. INTRODUCTION

The event reports provided in this session are from real-world applications. They have been edited only to the extent that the owner involved is not revealed. They provide us the opportunity to learn and improve our power system. We want to thank the engineers and technicians who share information and what they know for the benefit of our industry.

We provide a number of example case studies. These come from a wide variety of power system and protection applications. We have distribution, transmission, transformer, bus, generator, and motor event examples.

In each case, we provide the following:

- A brief introduction to the application and problem.
- The event reports required to solve the problem.
- References for future reading and further instruction.

Students are required to use their own personal computer with SEL Compass[®], ACSELERATOR QuickSet[®] SEL-5030 Software, and ACSELERATOR Analytic Assistant[®] SEL-5601 Software installed. These programs are available for download at no cost from www.selinc.com.

Students are invited to answer the questions asked in this document. These questions are intended to guide analysis, keep the class efforts focused in the same direction, and highlight the main lesson points. Please document the solution to each case study in the format of a Microsoft[®] Word document with appropriate software screen captures and notes.

Last, instructors are available to answer questions, share tips, and highlight lessons learned. Have fun!

II. DISTRIBUTION FEEDER FAULT

This event occurred on a distribution collector at a wind farm. For practical purposes, faults on the collector behave like faults on a radial feeder fed from a Dy1 transformer. The wind turbines do not contribute any significant fault current. The location and connection of the potential transformers (PTs) are not known at the time of publication.

Lightning arresters, one per phase, are positioned on the top of the steel support structure. Each arrester is connected by a jumper to the phase conductor. A bird caused a fault near one lightning arrester, which caused its jumper to blow loose and contact other phases.

Open the event report titled **2 – Distribution Feeder Fault 351S-6.cev** to analyze this case. See Fig. 1 for a screen capture from this event.

The relay involved was an SEL-351S-6. The instruction manual is provided as part of the class material and is also available at www.selinc.com.

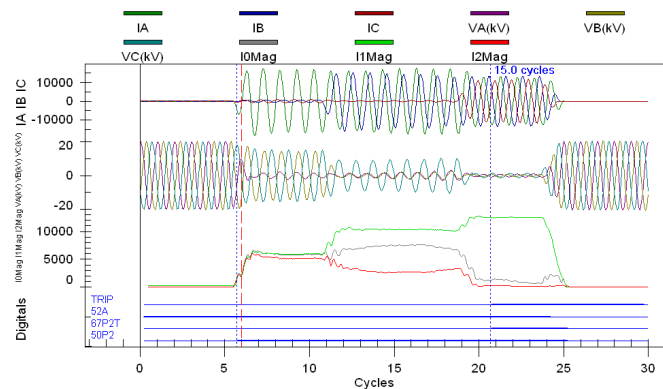

Fig. 1. Distribution Feeder Fault (2 – Distribution Feeder Fault 351S-6.cev)

Questions:

- II-a Before the fault, in what direction is power flowing?
- II-b What is the system phase rotation?
- II-c What type of fault occurred?
- II-d What protection element within the relay caused the trip?
- II-e How long did it take for the relay to operate?
- II-f How long did the breaker take to clear the fault?
- II-g Did the relay and protection system operate correctly and as expected?

Another event report from a different system is provided for comparison. Open the event report titled **2 – Distribution Feeder Fault 351A.cev** to analyze that case. See Fig. 2 for a screen capture from this event. The relay involved was an SEL-351A. The instruction manual is provided as part of the class material and is also available at www.selinc.com.

Note in Fig. 1 that the phase fault current is largest during the single-line-to-ground fault period. In Fig. 2, the phase fault current is largest during the three-phase fault period.

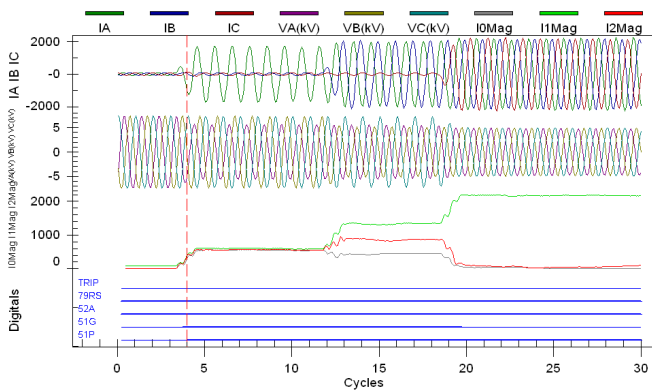

Fig. 2. Distribution Feeder Fault (2 – Distribution Feeder Fault 351A.cev)

Question:

II-h On a radial distribution feeder, what type of fault do you expect to produce the largest phase fault current? Does the type of transformer used as a source matter? Does the fault location make a difference? Can you provide an explanation for the fault type current magnitudes in these two event reports?

The SEL University classes PROT 301: Protecting Power Systems for Technicians and PROT 401: Protecting Power Systems for Engineers review necessary symmetrical components and fault analysis fundamentals. Register for these classes and more at www.selinc.com.

III. UNDERFREQUENCY LOAD-SHEDDING TEST

These events were recorded from laboratory tests. An SEL-451-5 was being applied for underfrequency load shedding. Laboratory tests were conducted to prove the protection scheme would perform as intended.

The scheme was designed to trip groups of 7 kV feeders at various underfrequency set points. The first group of feeders should have tripped at 58.7 Hz. A different group of feeders would have tripped at different frequencies. Therefore, frequency elements were programmed directly into individual output contacts. All frequency elements were originally connected by OR gates in the trip logic only to provide a local trip light-emitting diode (LED) indication; the trip logic was not used by any output contacts.

The feeders were on the low side of a 66 kV/7 kV transformer. The relay voltage inputs were fed from the 66 kV bus PTs.

A standard test set applied secondary voltages. The frequency of VA was lowered in steps, rather than using a ramp. Trip unlatch (TULO) was set for Option 3. With no current applied and no breaker status simulated during the test (see Page A.1.14 of the SEL-451-5 Instruction Manual), the trip will unlatch when trip conditions expire or after a minimum time of 12 cycles (TDUR3D).

Open the event report titled **3 – Frequency Load Shed Test One 451-5.cev** to analyze the first test. See Fig. 3 for a screen capture from that event. The relay involved was an SEL-451-5. The instruction manual is provided as part of the class material and is also available at www.selinc.com.

Three problems were noted by technicians. First, the output contact used by the underfrequency element 81D1T chattered continuously after the frequency was lowered below the set point, and it would not stop until the frequency was returned to normal. Second, the trip time for the underfrequency event was slightly longer than expected. Third, the frequency metering stopped tracking at 58.0 Hz, despite the test set being lowered below this level.

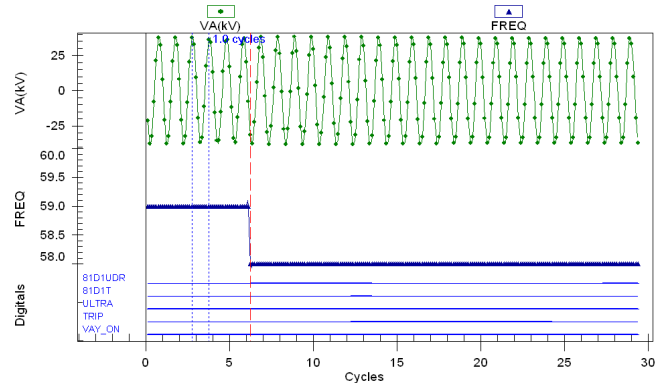

Fig. 3. Frequency Test 1 (3 – Frequency Load Shed Test One 451-5.cev)

Open the event report titled **3 – Frequency Load Shed Test Two 451-5.cev** to analyze the second test. See Fig. 4 for a screen capture from this event. The trip logic was changed for the second test, setting TR equal to NA. The only other change made for this test was the addition of the FREQOK (frequency tracking okay) and FREQZ (freeze frequency tracking) Relay Word bits to the digital elements recorded with event reports.

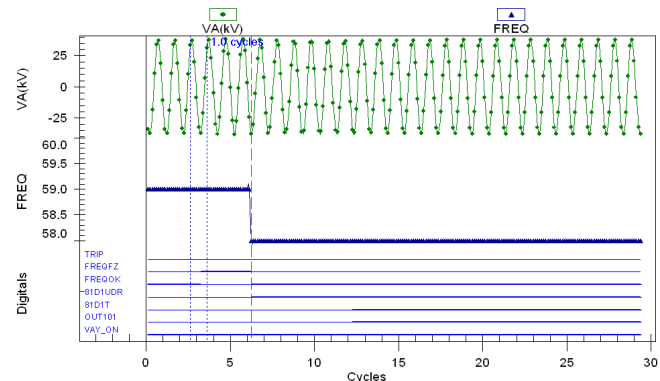

Fig. 4. Frequency Test 2 (3 – Frequency Load Shed Test Two 451-5.cev)

Questions:

- III-a Using event data, can you determine if the voltage magnitude applied is correct for this application?
- III-b At what point in the event data did the test set actually change frequency?

Open the event reports titled **5 – Transformer Differential Report 387A.cev** and **5 – Transformer Filtered Report 387A.cev** to analyze this event. See Fig. 8 and Fig. 9.

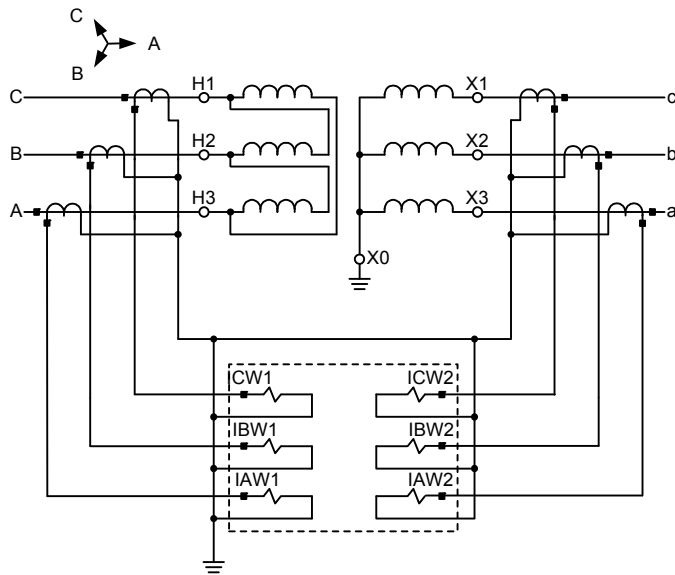

Fig. 7. Transformer Application

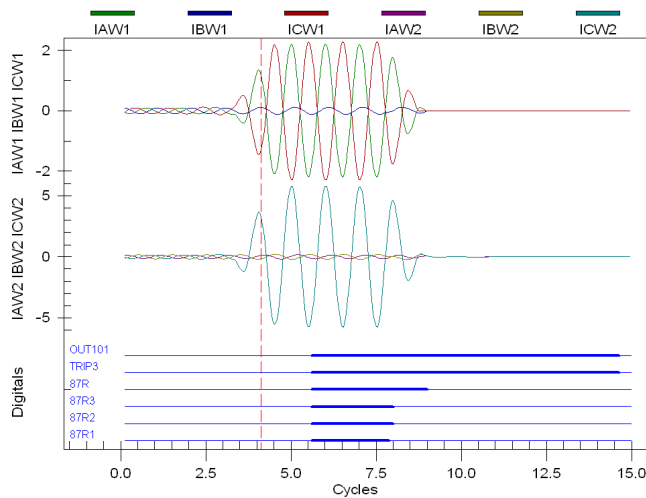

Fig. 8. Phase Currents (5 – Transformer Filtered Event 387A.cev)

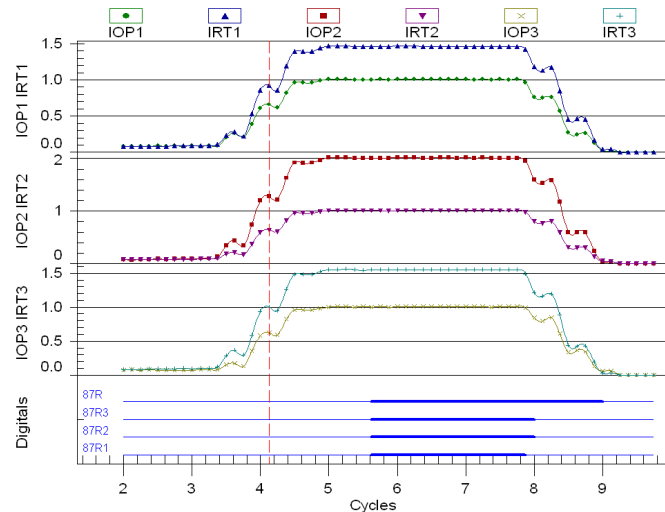

Fig. 9. Differential Signals (5 – Transformer Differential Report 387A.cev)

Questions:

- V-a Using the prefault phasors, can you confirm the system phase rotation?
- V-b Given the information about the system and the diagram shown in Fig. 7, can you determine the expected phase angle relationship across the transformer?
- V-c Using the prefault phasors, does the actual system match your expected phase angle relationship from question V-b?
- V-d Where was the fault (internal to the transformer or external to the protection zone)?
- V-e Was the transformer differential operation correct or incorrect for the fault location?
- V-f Is the relay set correctly?
- V-g Using the differential report data, was there any indication before the fault that a problem existed?

The technical paper “Proper Testing of Protection Systems Ensures Against False Tripping and Unnecessary Outages” is available at www.selinc.com and is recommended reading for more information on this subject.

VI. RESTRICTED EARTH FAULT OPERATION

Restricted earth fault (REF) protection in an SEL-387-6 was enabled on a 25 MVA transformer to provide a sensitive ground current differential zone of protection for the grounded-wye winding and low-side bus. See Fig. 10.

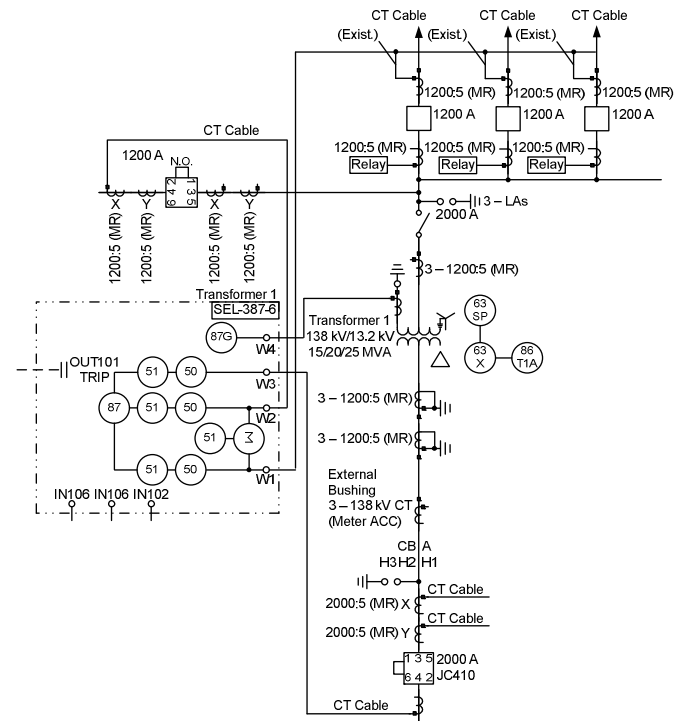

Fig. 10. REF Application

The SEL-387-6 Instruction Manual is provided as part of the class material and is available at www.selinc.com. Open the event report titled **6 – Transformer REF 387-6.cev** to analyze this event. See Fig. 11. Winding 1 feeders are radial loads.

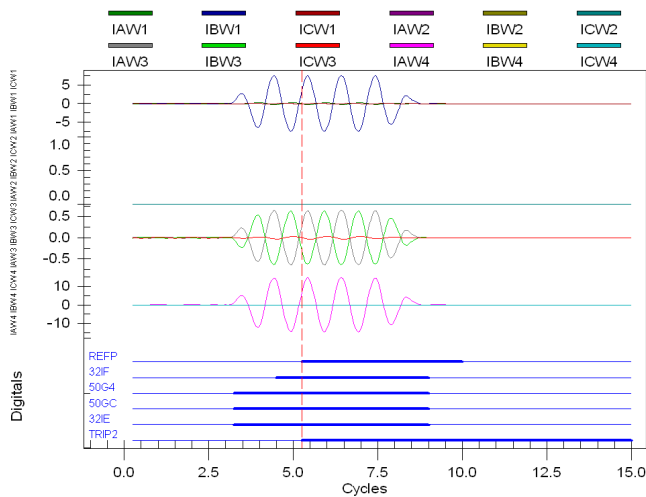

Fig. 11. REF Application (6 – Transformer REF 387-6.cev)

Questions:

- VI-a Where was the fault (internal to the transformer or external to the protection zone)?
- VI-b Was the tie breaker open or closed at the time of the event?
- VI-c What element operated to trip the transformer?
- VI-d Was the transformer relay operation correct or incorrect for the fault location?
- VI-e For an external ground fault, what phase angle relationship do you expect between the Winding 1 and Winding 4 currents?
- VI-f Why is the ground current magnitude on Winding 1 different than Winding 4?
- VI-g A current transformer (CT) wiring problem is suspected. Can you prove which winding has the error?

The technical paper “Analysis of an Autotransformer Restricted Earth Fault Application” is available at www.selinc.com and is recommended reading for more information on this subject.

VII. TRANSFORMER DIFFERENTIAL COMMISSIONING TEST

Engineers and technicians were on-site to witness the energization of a new 138 kV/12.47 kV substation. After putting some load on the distribution feeders, they noticed that the differential current measured by the SEL-587 was quite high, as a percentage of restraint. The load was very small, and there was some debate as to whether the transformer was ready to be put into service.

See Fig. 12. Two 1200:5 MRCTs, tapped at 900:5, are paralleled and connected to the Winding 1 inputs of the relay. A single 1200:5 MRCT, tapped at 1200:5, is connected to the Winding 2 inputs of the relay. The transformer is rated 12/16/20 MVA and 138 kV/12.47 kV. From Fig. 12, the polarity of H1 is connected to the nonpolarity of H2. A-phase is connected to H1, B-phase is connected to H2, and C-phase is connected to H3. The system phase rotation is ABC.

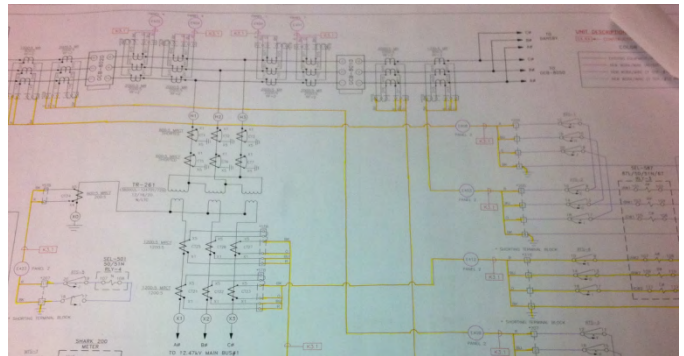

Fig. 12. Commissioning Example

The SEL-587 Instruction Manual is provided as part of the class material and is also available at www.selinc.com. Open the event report titled **7 – Transformer Commissioning 587.cev** and the settings file titled **7 – Transformer Commissioning Settings 587.pdf** to analyze this event.

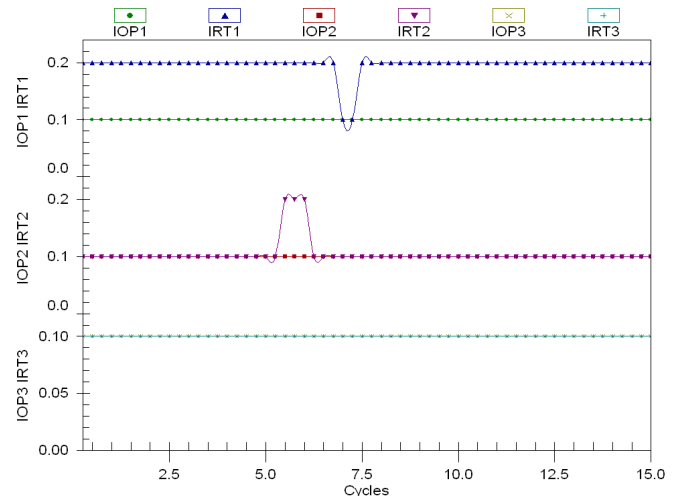

Fig. 13. IOP and IRT (7 – Transformer Commissioning Settings 587.pdf)

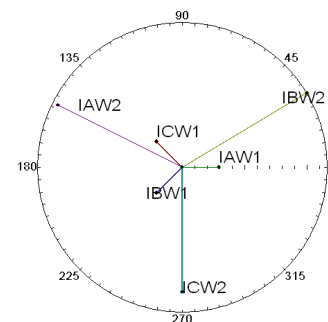

Fig. 14. Winding Currents (7 – Transformer Commissioning Settings 587.pdf)

Questions:

- VII-a Based on the differential and phasor data, would you put the transformer in service?
- VII-b Do the phase angle relationships match your expectations from the settings?
- VII-c Does the power into the transformer match the power out of the transformer?
- VII-d Why would an engineer turn off the MVA setting in an SEL-587 Relay?
- VII-e Calculate TAPx settings for this application. Do your calculations match the settings?
- VII-f Are your calculated TAPx settings within the range of the relay?
- VII-g Can you propose a solution?

The technical paper “Lessons Learned Through Commissioning and Analyzing Data From Transformer Differential Installations” is available at www.selinc.com and is recommended reading for more information on this subject.

VIII. LINE CURRENT DIFFERENTIAL COMMISSIONING TEST

Technicians were attempting to perform a satellite-synchronized end-to-end test of a transmission line protection scheme while the line was out of service. The relays and scheme had been installed for some time and had worked correctly during previous system faults.

SEL-311L line current differential relays were used for primary and backup protection at each terminal. The SEL-311L Instruction Manual is provided as part of the class material and is also available at www.selinc.com.

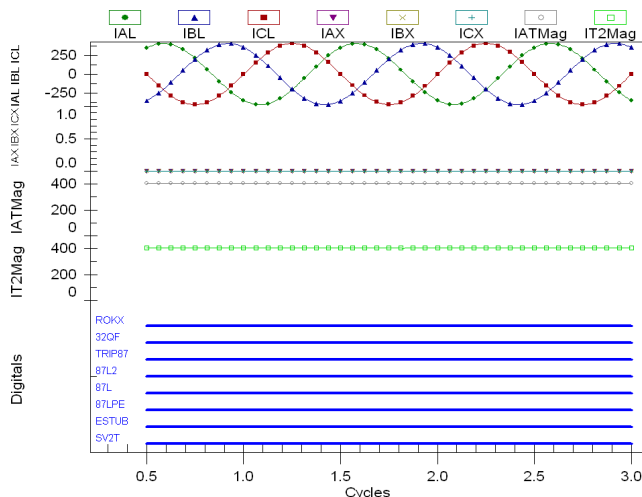

Fig. 15. Line Current Differential Commissioning (8 – Transmission Line 87L Test 311L.cev)

Open the event report titled **8 – Transmission Line 87L Test 311L.cev** to analyze this event. This event was triggered manually while local and remote currents were simultaneously applied to the relays using satellite-synchronized test sets. The event data are from Terminal A of a two-terminal line. We will refer to the remote line end as Terminal B.

During the test, several observations were made:

- The local Terminal A measures local (A) currents but does not show its remote (Terminal B) currents in metering or event data.
- The remote Terminal B measures its local (B) currents but does not show its remote (Terminal A) currents in metering or event data.
- The fiber-optic channel tests okay, and monitoring shows the channel to be in service (ROKX = 1).
- When the local Terminal A primary relay fiber is connected to itself (in loopback) or to the local Terminal A backup relay, it does not meter remote or received currents.
- When the remote Terminal B primary relay fiber is connected to itself (in loopback) or to the local Terminal B backup relay, it does meter remote or received currents.
- The local relay tripped when current was applied.

Questions:

- VIII-a Do the phase angle relationships match your expectations from the settings?
- VIII-b How do you explain the trip when only 1 A balanced secondary currents are applied at each line terminal?
- VIII-c Do you think it is likely that the relays have failed? Justify your answer.
- VIII-d Can you explain why the channel monitor is healthy (ROKX = 1) but no remote currents are being metered?
- VIII-e Can you explain why the remote relays work when in loopback mode and the local relays do not work in loopback mode?

IX. DELAYED FAULT CLEARING ON TRANSMISSION LINE

A crew was installing new structures for a transmission line rebuild and upgrade project. They were working in the existing right-of-way of an energized transmission line. The truck came in close enough proximity to the transmission line to cause a flashover.

The SEL-311C transmission line relays are used for primary and backup protection at each terminal. The SEL-311C Instruction Manual is provided as part of the class material and is also available at www.selinc.com.

Substations are referenced as Terminal A and Terminal B. There are six event reports for this case study. They are named **9 – A Delayed Fault Clearing xyz Event 311C.cev** and **9 – B Delayed Fault Clearing xyz Event 311C.cev** (xyz represents the first, second, or third in order of when they occurred).

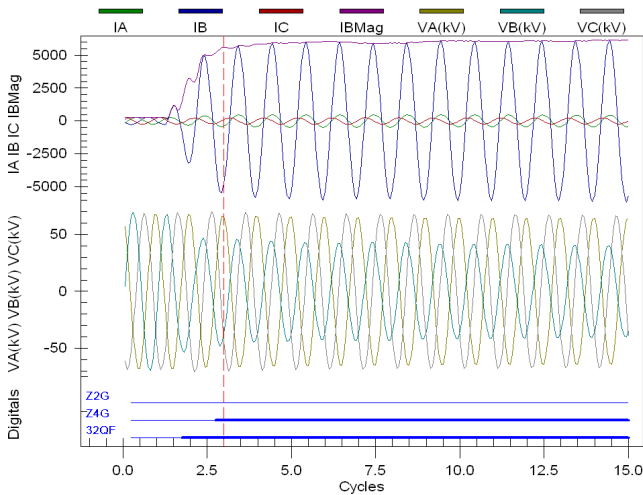

Fig. 16. First Event, Terminal A (9 – A Delayed Fault Clearing 1st Event 311C.cev)

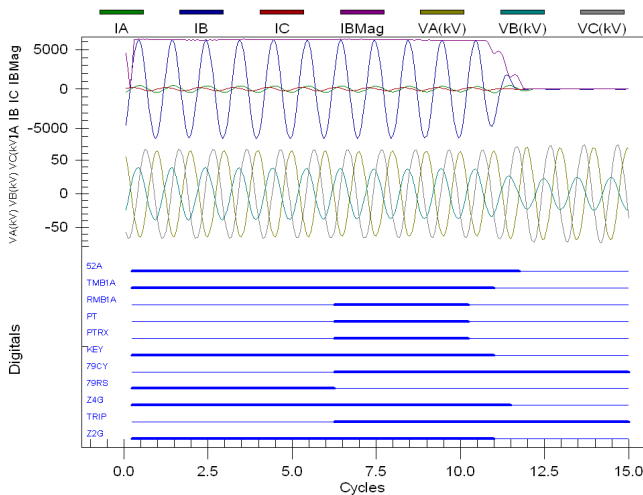

Fig. 17. Second Event, Terminal A (9 – A Delayed Fault Clearing 2nd Event 311C.cev)

Fig. 18 shows an automatic reclose. It was determined that human error caused a hot-line tag to be taken on the wrong line and not the energized line that the crew was working under. Luckily, no one was injured in this event.

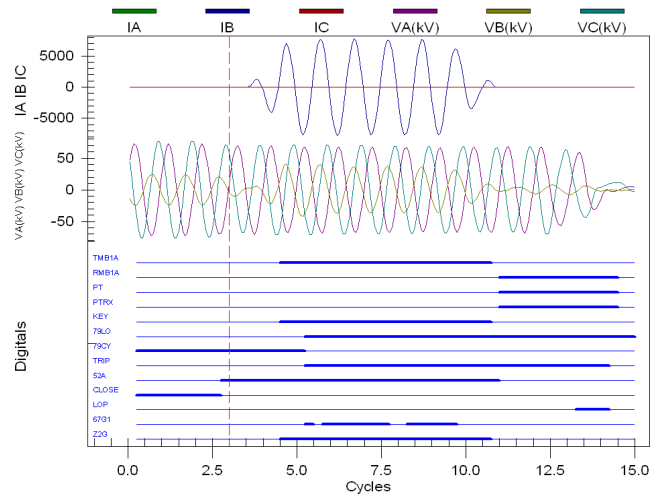

Fig. 18. Third Event, Terminal A (9 – A Delayed Fault Clearing 3rd Event 311C.cev)

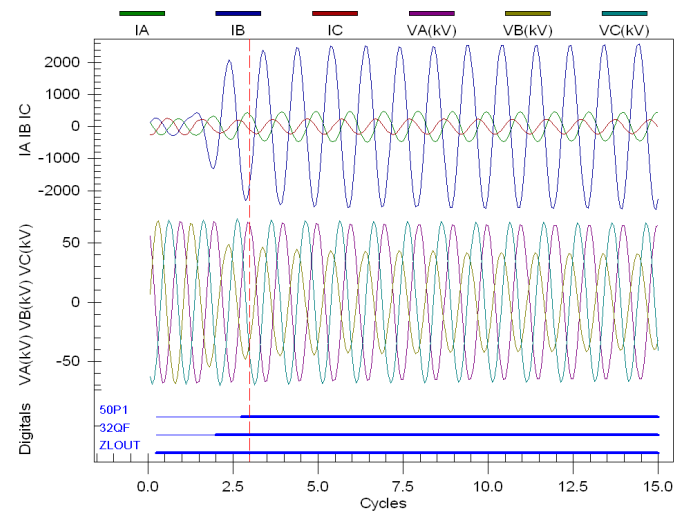

Fig. 19. First Event, Terminal B (9 – B Delayed Fault Clearing 1st Event 311C.cev)

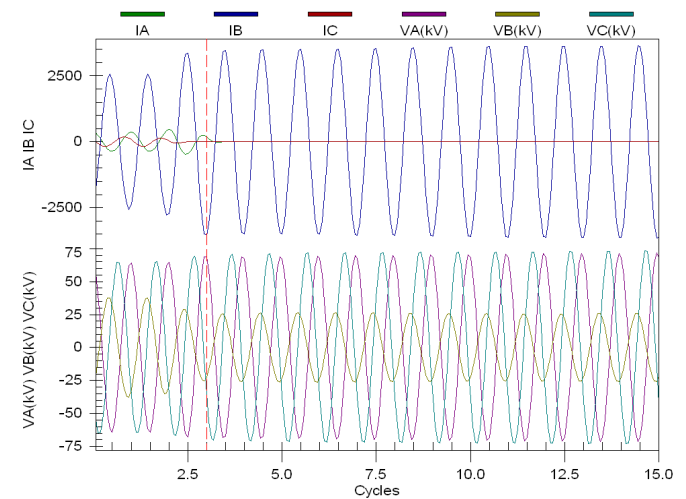

Fig. 20. Second Event, Terminal B (9 – B Delayed Fault Clearing 2nd Event 311C.cev)

Z4G picks up and starts timing. Notice the load current goes away (the remote end has opened).

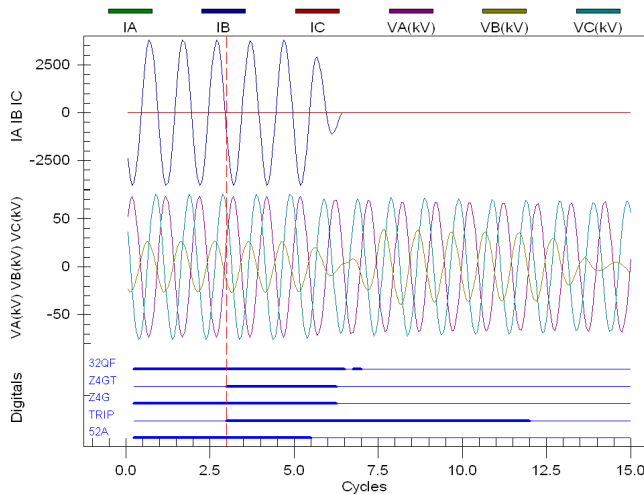

Fig. 21. Third Event, Terminal B (9 – B Delayed Fault Clearing 3rd Event 311C.cev)

Questions:

- IX-a In the first event report from Terminal A, how can a fault located at 0.62 miles on a 2.96-mile-long line be in Zone 4 and not Zone 1?
- IX-b Using the first and second event report from Terminal A, how long did it take for Terminal A to trip?
- IX-c Terminal A trips via its permissive overreaching transfer trip (POTT) scheme logic. Can you explain why the received permission-to-trip PT signal is precisely 4.0 cycles long?
- IX-d What triggered the third event report from Terminal A?
- IX-e What triggered the first event report from Terminal B?
- IX-f What triggered the second event report from Terminal B?
- IX-g Why do IA and IC currents go to zero in the second event report from Terminal B?
- IX-h How long does Terminal B take to clear the fault?
- IX-i What relay setting change can you suggest to drastically improve tripping sensitivity to high-resistance faults and therefore speed up tripping?

The technical paper “Very High-Resistance Fault on a 525 kV Transmission Line – Case Study” is available at www.selinc.com and is recommended reading for more information on this subject.

X. DOUBLE-ENDED FAULT LOCATION

A fault occurred on an 82-mile-long 161 kV line. The left terminal (R) provided a fault location estimate of 13.95 miles (from the left). The right terminal (S) provided a fault location estimate of 56.5 miles (from the right).

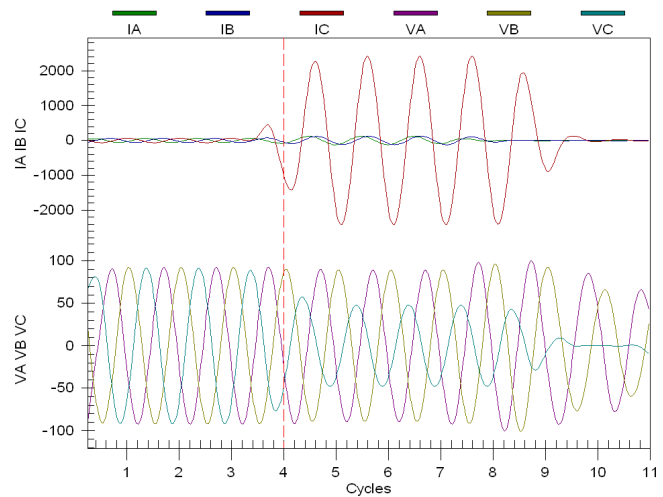

Fig. 22. LG Fault (10 – Double End Fault Location R 121G.eve)

Engineers know these estimates are in error because they do not provide a common location on the line, do not add up to 82 miles, and do not match the actual location of the fault, as determined by visual inspection and damage.

The actual location of the fault was about 17.5 miles from Terminal R.

The SEL-121G-3 and SEL-221G-3 transmission line relays are used at each terminal. The instruction manual is provided as part of the class material and is also available at www.selinc.com.

Substations are referenced as Terminal R and Terminal S. There are two event reports for this case study. They are named **10 – Double End Fault Location R 121G.eve** and **10 – Double End Fault Location S 121G.eve**.

A Mathcad® 2000 worksheet is also provided (**10 – Two-ended_Neg-Seq_FLoc_-dac.mcd**) for those who would like to use it.

Question:

- X-a Using the event data from each terminal, use the two-ended negative-sequence fault location method to determine a more accurate fault location estimate.

The technical paper “Impedance-Based Fault Location Experience” is available at www.selinc.com and is recommended reading for more information on this subject.

XI. BUS DIFFERENTIAL OPERATION

An engineer has applied two high-impedance bus differential relays on the same bus and connected the differential elements in series. This was done to provide backup protection against a single relay failure. The high-impedance bus protection is assumed to have two failure modes. One failure mode is a relay disabled (power supply, processor failure, and so on), but with its high impedance still in the CT circuit. The other failure mode is a metal oxide varistor (MOV) failed shorted, removing the high-impedance input of the relay.

For internal faults, the series connection limits the minimum sensitivity of the scheme. However, for solidly

grounded systems, current sensitivity for bus faults is rarely a problem.

The differential element voltage setting was calculated using the standard CT plus lead resistance formula and a safety factor of two. By connecting the two voltage elements in series, a second safety factor of two is effectively applied because each relay will only see half the voltage at the junction point for an external fault.

For internal faults, the CTs will see a 4000-ohm burden instead of 2000 ohms. The CTs are 1200:5, C800. The 87 elements are set to pick up at 146 V.

SEL-587Z Relays were used in this application. The instruction manual is provided as part of the class material and is also available at www.selinc.com.

Raw and filtered event reports from one of the series-connected SEL-587Z Relays are provided for this case study. The other relay data are identical. The events are named **11 – High Impedance Bus Trip 587Z Filtered.cev** and **11 – High Impedance Bus Trip 587Z Raw.cev**.

Lockout relay contacts were wired in parallel with the high-impedance inputs on the relays so that the inputs were shorts immediately after a trip. Overcurrent inputs were connected in series with the voltage inputs to measure the current through the high-impedance circuit.

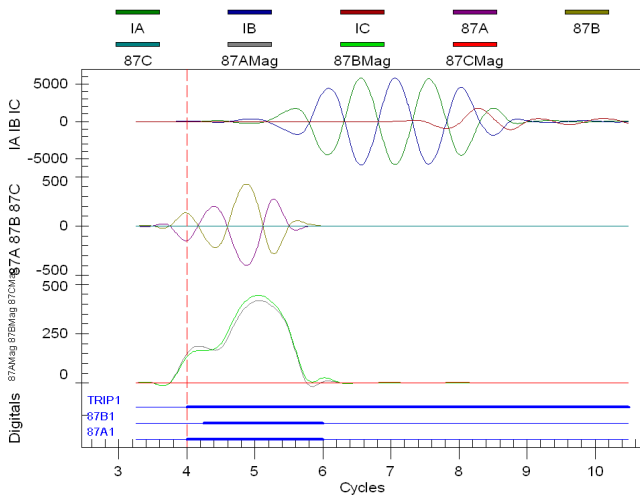

Fig. 23. Filtered Bus Differential Operation (11 – High Impedance Bus Trip 587Z Filtered.cev)

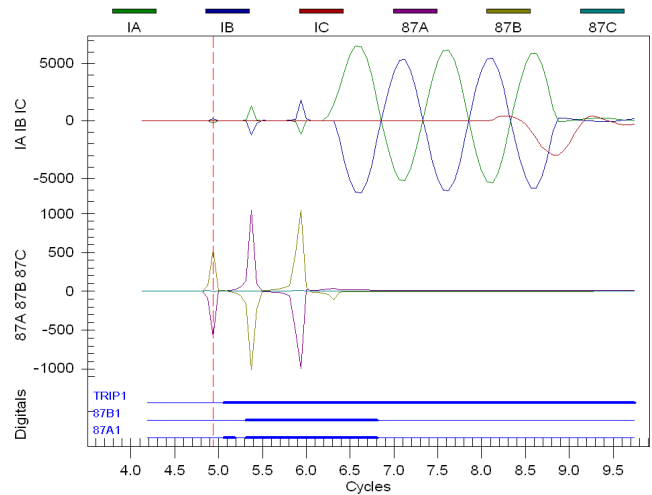

Fig. 24. Raw Bus Differential Operation (11 – High Impedance Bus Trip 587Z Raw.cev)

Questions:

- XI-a Was this an internal or external fault?
- XI-b What element caused the trip?
- XI-c In the oscillograph data, why does the current signal seemingly lag or follow the voltage?
- XI-d Can you explain the difference in waveforms in the raw event data (sharp peaks versus smooth sinusoids)?

The technical paper “Application Guidelines for Microprocessor-Based High-Impedance Bus Differential Relays” is available at www.selinc.com and is recommended reading for more information on this subject.

XII. MOTOR TRIP

This event is from an induction motor that protects a boiler water-circulating pump at a power plant. The motor was running at the time of this event. See Fig. 25.

The SEL-710 motor protection relay protects the motor. The instruction manual is provided as part of the class material and is also available at www.selinc.com.

There is one event report for this case study. The event is named **12 – Motor Trip 710.cev**.

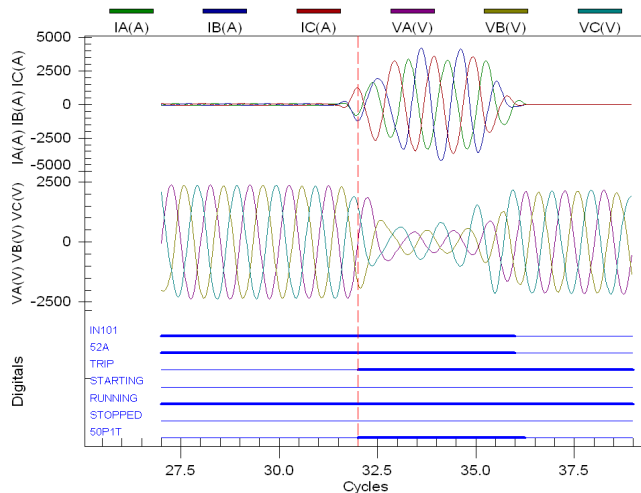

Fig. 25. Motor Trip (12 – Motor Trip 710.cev)

Questions:

- XII-a What happened to the motor?
- XII-b Can you prove the event was not caused by a load jam or jammed router?
- XII-c Can you prove that the motor did not stall because of low voltage?
- XII-d What element caused the trip?
- XII-e Does this application use a fused contactor or a circuit breaker?
- XII-f Did the tripping element operate correctly?

The textbook *AC Motor Protection* by Stanley E. Zocholl is available at www.selinc.com and is recommended reading for more information on this subject.

XIII. GENERATOR CLOSE

A 112 MVA steam unit was closed and generated the event shown in Fig. 26. Operators scrambled to determine if the unit tripped because of a fault or some other problem.

The SEL-300G generator relay was used to protect the unit. The instruction manual is provided as part of the class material and is also available at www.selinc.com.

There is one event report for this case study. It is named **13 – Generator Close 300G.cev**.

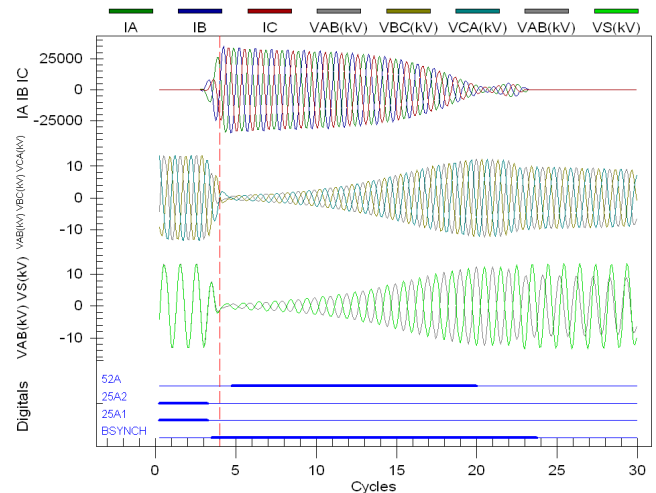

Fig. 26. Generator Close (13 – Generator Close 300G.cev)

Questions:

- XIII-a What was the maximum current magnitude?
- XIII-b What element triggered this event report?
- XIII-c What conditions could produce this much current at the terminals of this generator?
- XIII-d If this was a fault, what would the current magnitude look like from the generator?
- XIII-e Was the generator in synchronism with the system prior to the breaker close?
- XIII-f What is the root cause of the problem?
- XIII-g Why did the relay out-of-step (78) function not operate for this event?

XIV. BIOGRAPHY

David Costello graduated from Texas A&M University in 1991 with a BSEE. He worked as a system protection engineer at Central Power and Light and Central and Southwest Services in Texas and Oklahoma and served on the System Protection Task Force for ERCOT. In 1996, David joined Schweitzer Engineering Laboratories, Inc., where he has served as a field application engineer and regional service manager. He presently holds the title of senior application engineer and works in Fair Oaks Ranch, Texas. He is a senior member of the IEEE and a member of the planning committee for the Conference for Protective Relay Engineers at Texas A&M University. David was a recipient of the 2008 Walter A. Elmore Best Paper Award from the Georgia Institute of Technology Protective Relaying Conference and a contributing author to the reference book *Modern Solutions for the Protection, Control, and Monitoring of Electric Power Systems*.